

HRM .075 x .075 HYPERBOLOID SERIES

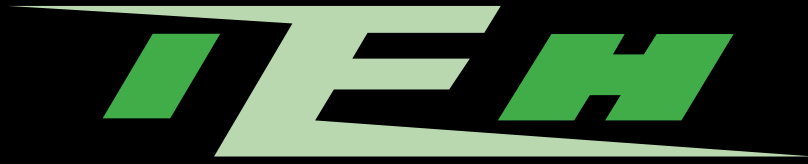

HYPERBOLOID CONNECTORS

FOR SUPERIOR PERFORMANCE IN ALL APPLICATIONS

IEH CORPORATION ISO 9001:2000

SMALL BUSINESS-HUB-ZONE CERTIFIED

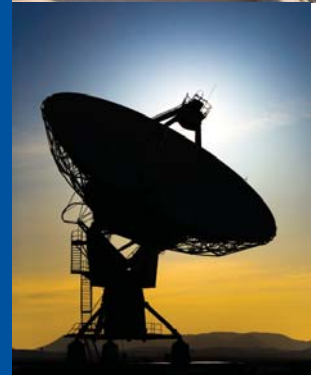
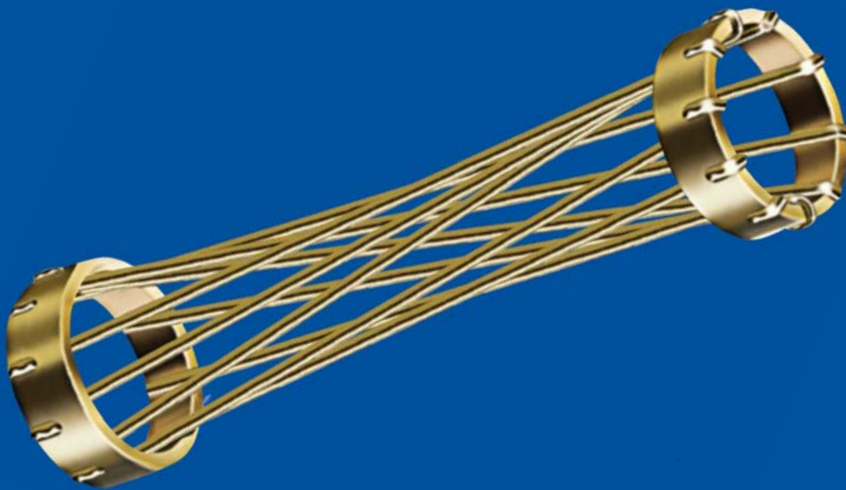

www.iehcorp.com

CONTENTS

HRM SERIES - .075 x .075 CONNECTORS

PAGE

- 2 Introduction
- 3 Specifications

2 - ROW CONNECTORS [010-100 CONTACTS]

- 4 2 - Row Ordering Chart
- 5 FAE - Receptacle, Stacking, Straight
- 6 FBE, FDE, FSE, FVE, FWE - Receptacle, Straight
(Flex Cable, Dip Solder, Solder Cup, Compliant, Wire Wrap)
- 7 FEE - Receptacle, Dip Solder, Right Angle
- 8 FRE - Receptacle, Surface Mount
- 9 RAE - Plug, Stacking
- 10 RBE, RDE, RSE, RVE, RWE - Plug, Straight
(Flex Cable, Dip Solder, Solder Cup, Compliant, Wire Wrap)
- 11 MEE, MLE - Plug, Right Angle (Dip Solder, Compliant)
- 12 MRE - Plug, Surface Mount

3 - ROW CONNECTORS [011-206 CONTACTS]

- 13 3 - Row Ordering Chart
- 14 FAE - Receptacle, Stacking, Straight
- 15 FBE, FDE, FSE, FVE, FWE - Receptacle, Straight
(Flex Cable, Dip Solder, Solder Cup, Compliant, Wire Wrap)
- 16 FEE - Receptacle, Dip Solder, Right Angle
- 17 MAE - Plug, Stacking
- 18 MBE, MDE, MSE, MVE, MWE - Plug, Straight
(Flex Cable, Dip Solder, Solder Cup, Compliant, Wire Wrap)
- 19 MEE, MLE - Plug, Right Angle (Dip Solder, Compliant)

APPENDIX

- 20 Termination Style 2 Row - Receptacle
- 21 Termination Style 2 Row - Plug
- 22 Termination Style 3 Row - Receptacle
- 23 Termination Style 3 Row - Plug
- 24 Hardware Style
- 25 Polarization Chart A, B, H, K, L, M, N, O, P, T, X
- 26 F & G Hardware Detail
- 27 Polarization Chart F & G
- 28 PWB Patterns - Plug
- 29 PWB Patterns - Receptacle

The HYPERBOLOID contact is an advanced design that satisfies performance requirements previously considered impossible. Radically different in concept, it is used in connectors having the highest standards of performance. The distinguishing feature of the HYPERBOLOID socket is the hyper-boloid-shaped sleeve formed by straight wires strung at an angle to the longitudinal axis. Viewed from the side, you see a curve defined by a series of apparent short straight line segments which are tangent lines to points along a hyperbolic curve. This geometry provides for a design which has a decreasing circumscribed circle when viewed from the entry. It begins larger than the pin acceptance diameter and is less than this same diameter at the center. When the pin is inserted into this sleeve, the wires stretch, well within elastic limits, to accommodate it. In so doing, the wires wrap themselves around the pin providing a number of continuous line contact paths. The illustration below will assist in visualization.

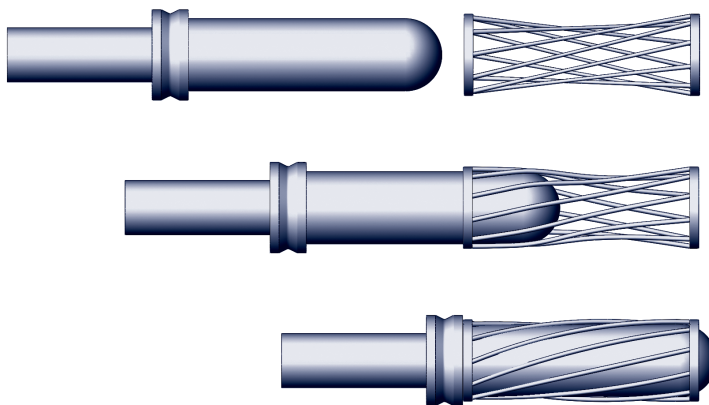

The actual physical construction of the contact involves several components. The wires are strung on an internal wire carrier (inner sleeve) which is subsequently capped or enclosed by a front outer ring (front sleeve) and rear ring which includes the termination configuration (terminal). All components to the assembly are completely finished with the specified electroplating prior to assembly. The wires are continuous process plated on reel before use. In this manner, interface finish requirements can be controlled very closely without the common problems of gradient, shadow, or other finish imperfections often appearing in alternative designs. Very often, this processing feature permits the specifier to reduce precious metal content with resultant savings. Joints are calculated interference fits, insuring gas tight interfaces between all elements of the HYPERBOLOID construction. An exploded view is provided next.

The unique geometry, precision processing, and careful attention to quality result in a highly desirable contact design which provides:

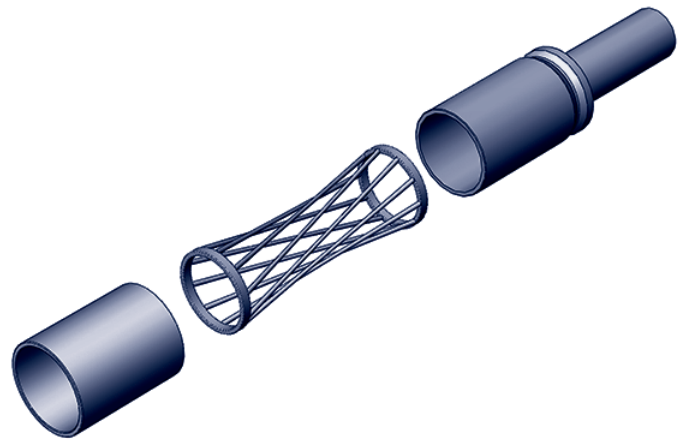

- **VLIF (Very Low Insertion Force):** Common sizes #22 and less average under one ounce per contact.
- **Extraordinary Resistance to Shock & Vibration:** Tests exceeding 300 g's without discontinuity.
- **Duty Cycle Exceeding 100,000 Mate/Demate:** The burnishing action of the wires on the pin surface is non-destructive. Unlike the "plow" and scrape action of common designs, HYPERBOLOID's gentle mating action enhances life.
- **Low, Low Contact Resistance:** The multiplicity of line contact, as opposed to point contact in other designs, provides an excellent interface exhibiting low contact resistance (often less than 1/2 of MIL spec. allowances). This characteristic also provides for a cooler running contact under load.
- **Improved Current Carrying Capacity:** The low contact resistance gives a lower °C rise from ambient under load. This feature often allows the user to operate the same size contact under higher load.
- **Highest Reliability:** In use for over 40 years under the most demanding conditions HYPERBOLOID has proven itself to be the leading design for integrity and reliability. On space platforms, ships and boats at sea, land vehicles, fighter and transport aircraft, missiles, torpedoes, medical and transplant electronics, industrial and environmental controls, rail, construction, ATE and test equipment, PGA sockets, test interface stations, and other applications, HYPERBOLOID has lived up to its promise of the highest reliability connector available.

SPECIFICATIONS

MATERIALS:

Pin Contacts:	PhBr per ASTM B139, BeCu per ASTM B196 or B197, or CU alloy
Socket Contacts:	
Contact Wires:	BeCu per ASTM B196, or B197
Termination:	PhBr per ASTM B139 or Cu alloy
Support Elements:	Cu alloy
SMT Leads:	PhBr per ASTM B139
Hardware:	Corrosion resistant steel per ASTM A582 ('D' shaped guide receptacles are BeCu per ASTM B196 or B197) or Cu alloy
Insulator:	Modified polyphenylene sulfide per MIL-M-24519, Type GST-40F

FINISHES:

Pin Contacts:	Gold per ASTM B488 Type II, Class 1.27, Code C over Nickel, 0.000050 min., per MIL-DTL-55302 over Copper per SAE AMS 2418 or ASTM B734
Socket Contacts:	
Contact Wires:	Gold per ASTM B488 Type II, Class 1.27, Code C over Nickel, 0.000050 min., per MIL-DTL-55302 over Copper per SAE AMS 2418 or ASTM B734
Termination:	Gold per ASTM B488, Class 0.50, Grade C over Nickel, 0.000050 min., per MIL-DTL-55302 over Copper per SAE AMS 2418 or ASTM B734 or solder dip over Nickel, 0.000050 min., per MIL-DTL-55302 over Copper per SAE AMS 2418 or ASTM B734
Support Elements:	Nickel, 0.000050 min., over Copper per SAE AMS 2418 or ASTM B734
SMT Leads:	Tin/Lead per SAE-AMS-P-81728
Hardware:	Passivate per SAE-AMS2700 except BeCu hardware to be Nickel plate, 0.000050 min.

PERFORMANCE:

Current Rating:	3* amp continuous (higher ratings may be supported-contact factory)
Insulation Resistance:	5000 megaohms min. – EIA-364-21 & MIL-DTL-55302 (par. 4.5.8)
Contact Resistance:	5 milliohms max, - EIA-364-06 & MIL-DTL-55302 (par. 4.5.5)
Test Voltage (DWV):	750 VAC RMS @ sea level - EIA-364-20 & MIL-DTL-55302 (par. 4.5.7.1) 250 VAC RMS @ 70,000 ft.
Temperature:	-65°C to +125°C (-86°F to +257°F)
Mating Force:	0.15 lbs. x number of contacts, max. - MIL-STD-55302 (par. 4.5.4)
De-mating Force:	0.03 lbs. x number of contacts, min. - MIL-STD-55302 (par. 4.5.4)
Contact Life:	100,000 mating cycles – Exceeds MIL-DTL-55302 (par. 4.5.9)
Solderability:	IPC/EIA J-STD-002, Category 3
Humidity:	IAW EIA-364-31, Method IV, except 7A & 7B (not required)
Vibration:	IAW EIA-364-28 & MIL-DTL-55302 (par. 4.5.10)
Shock:	IAW EIA-364-27 & MIL-DTL-55302 (par. 4.5.14)
Salt Spray:	IAW EIA-364-26 & MIL-DTL-55302 (par. 4.5.11)
Temperature Cycling:	IAW EIA-364-32 & MIL-DTL-55302 (par. 4.5.13)

DIMENSIONS:

Catalog product dimensions are nominal. For linear and positional tolerances, contact factory.

* Ampacity ratings shown are derated in accordance with the published military specifications. For stand-alone, full service ratings, supported by test data, please refer to IEH's Contacts Catalog, or contact the factory.

All information contained herein is believed to be reliable as of the date of publication, but is subject to change without notice. Current product drawings and specifications are available upon request from IEH.

IEH warrants its products to be free of defects affecting normal use. If any shipment is found to be defective we will accept return for repair or replacement at our option within one year of shipment. IEH is not responsible for incidental or consequential damages arising out of the use of our products.

ORDERING CHART
.075 X .075 SPACING

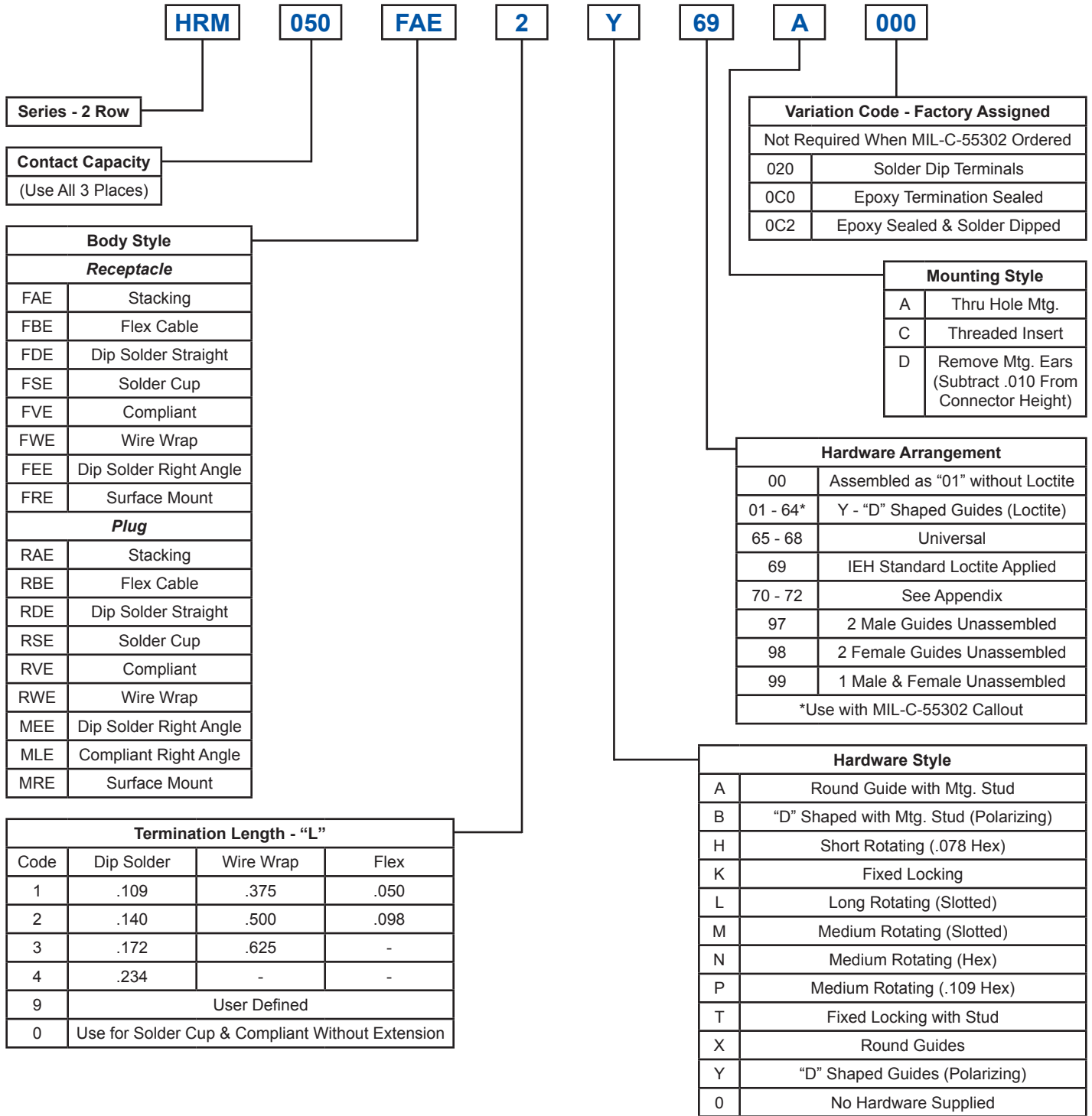

Series - 2 Row

Contact Capacity
(Use All 3 Places)

Body Style	
Receptacle	
FAE	Stacking
FBE	Flex Cable
FDE	Dip Solder Straight
FSE	Solder Cup
FVE	Compliant
FWE	Wire Wrap
FEE	Dip Solder Right Angle
FRE	Surface Mount
Plug	
RAE	Stacking
RBE	Flex Cable
RDE	Dip Solder Straight
RSE	Solder Cup
RVE	Compliant
RWE	Wire Wrap
MEE	Dip Solder Right Angle
MLE	Compliant Right Angle
MRE	Surface Mount

Termination Length - "L"			
Code	Dip Solder	Wire Wrap	Flex
1	.109	.375	.050
2	.140	.500	.098
3	.172	.625	-
4	.234	-	-
9	User Defined		
0	Use for Solder Cup & Compliant Without Extension		

Variation Code - Factory Assigned	
Not Required When MIL-C-55302 Ordered	
020	Solder Dip Terminals
0C0	Epoxy Termination Sealed
0C2	Epoxy Sealed & Solder Dipped

Mounting Style	
A	Thru Hole Mtg.
C	Threaded Insert
D	Remove Mtg. Ears (Subtract .010 From Connector Height)

Hardware Arrangement	
00	Assembled as "01" without Loctite
01 - 64*	Y - "D" Shaped Guides (Loctite)
65 - 68	Universal
69	IEH Standard Loctite Applied
70 - 72	See Appendix
97	2 Male Guides Unassembled
98	2 Female Guides Unassembled
99	1 Male & Female Unassembled
*Use with MIL-C-55302 Callout	

Hardware Style	
A	Round Guide with Mtg. Stud
B	"D" Shaped with Mtg. Stud (Polarizing)
H	Short Rotating (.078 Hex)
K	Fixed Locking
L	Long Rotating (Slotted)
M	Medium Rotating (Slotted)
N	Medium Rotating (Hex)
P	Medium Rotating (.109 Hex)
T	Fixed Locking with Stud
X	Round Guides
Y	"D" Shaped Guides (Polarizing)
0	No Hardware Supplied

RECEPTACLE, STACKING STYLE FAE

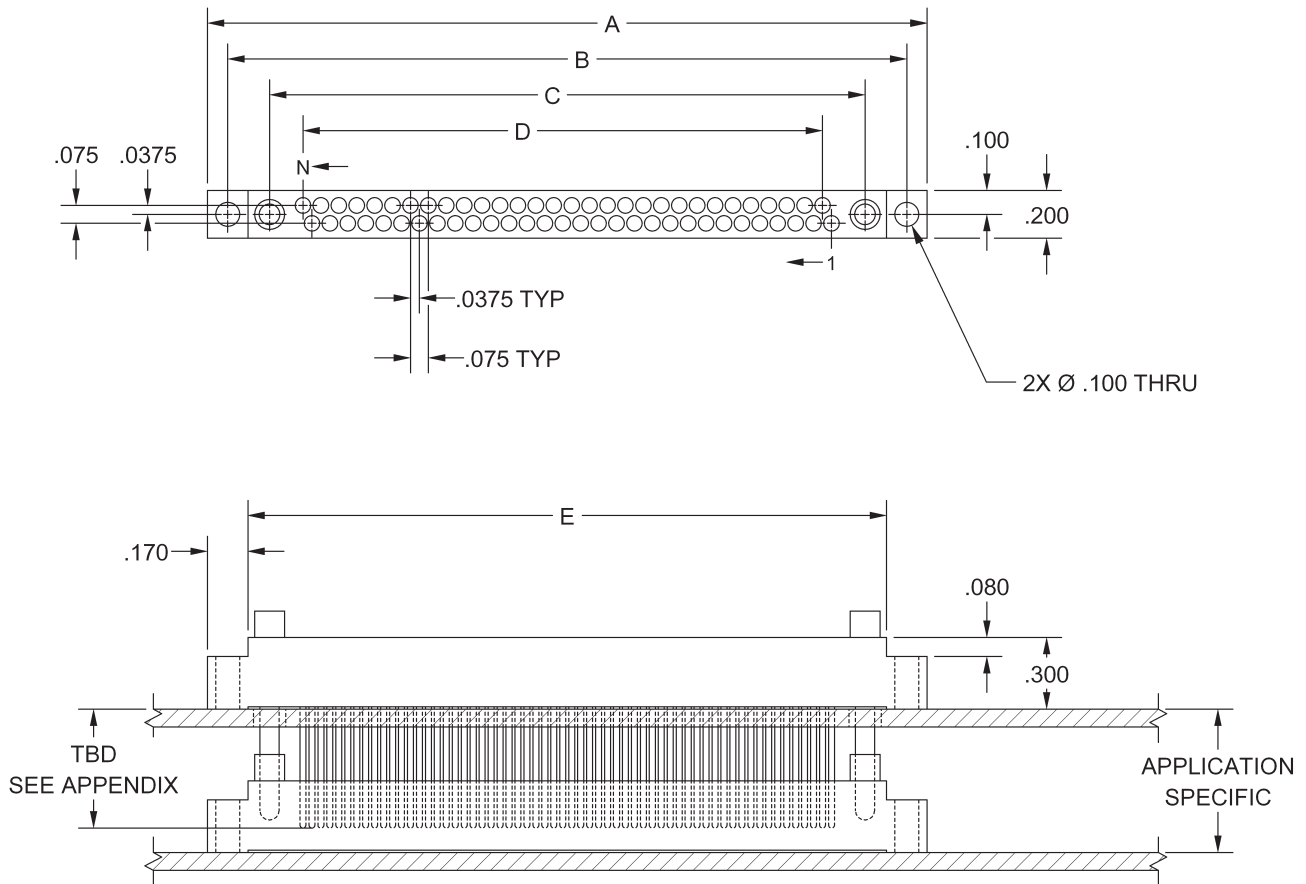

DIMENSIONS					
'N' Contacts	A	B	C	D	E
010	1.138	.968	.618	.300	.798
020	1.513	1.343	.993	.675	1.173
030	1.888	1.718	1.368	1.050	1.548
040	2.263	2.093	1.743	1.425	1.923
050	2.638	2.468	2.118	1.800	2.298
060	3.013	2.843	2.493	2.175	2.673
070	3.388	3.218	2.868	2.550	3.048
080	3.763	3.593	3.243	2.925	3.423
090	4.138	3.968	3.618	3.300	3.798
100	4.513	4.343	3.993	3.675	4.173

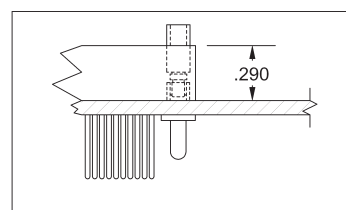

ALTERNATE PWB MOUNTING VIA
HARDWARE (MOUNTING EARS
REMOVED)

**REFER TO APPENDIX FOR TERMINATION
DETAILS, HARDWARE STYLES, POLAR-
IZATION CHART, MOUNTING STYLES,
VARIATION CODES, AND PWB PATTERNS**

**RECEPTACLE, STRAIGHT
STYLE FBE, FDE, FSE, FVE, FWE**

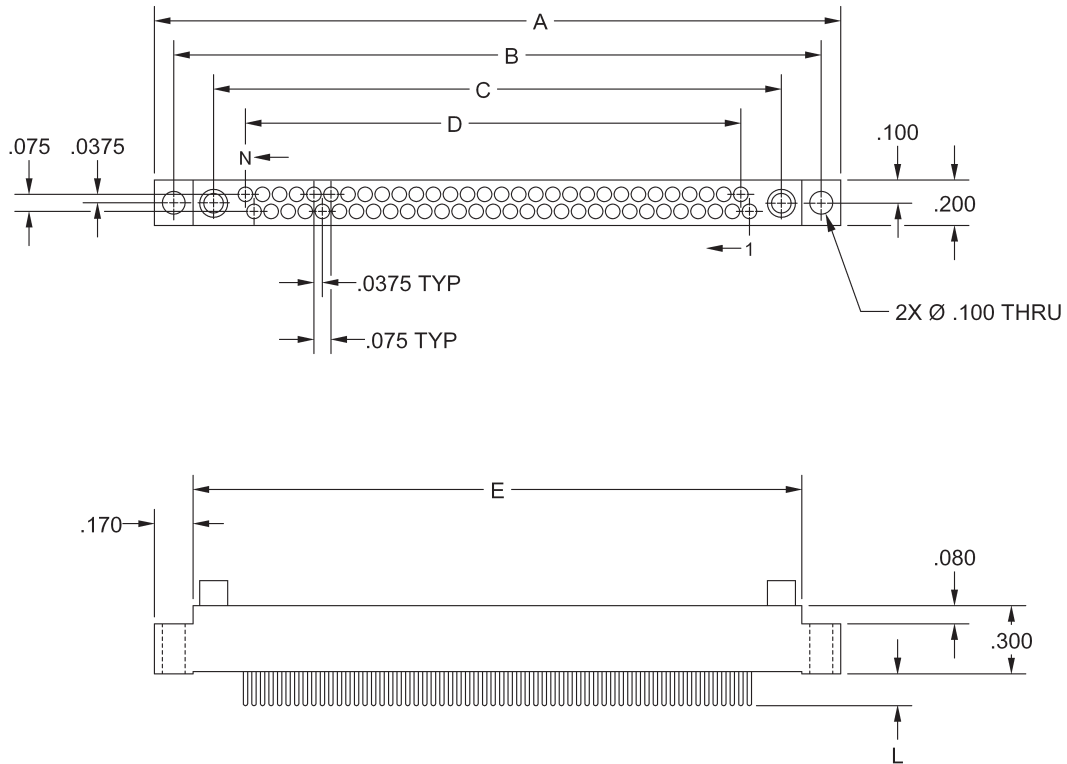

DIMENSIONS					
'N' Contacts	A	B	C	D	E
010	1.138	.968	.618	.300	.798
020	1.513	1.343	.993	.675	1.173
030	1.888	1.718	1.368	1.050	1.548
040	2.263	2.093	1.743	1.425	1.923
050	2.638	2.468	2.118	1.800	2.298
060	3.013	2.843	2.493	2.175	2.673
070	3.388	3.218	2.868	2.550	3.048
080	3.763	3.593	3.243	2.925	3.423
090	4.138	3.968	3.618	3.300	3.798
100	4.513	4.343	3.993	3.675	4.173

**REFER TO APPENDIX FOR TERMINATION
DETAILS, HARDWARE STYLES, POLAR-
IZATION CHART, MOUNTING STYLES,
VARIATION CODES, AND PWB PATTERNS**

RECEPTACLE, RIGHT ANGLE STYLE FEE

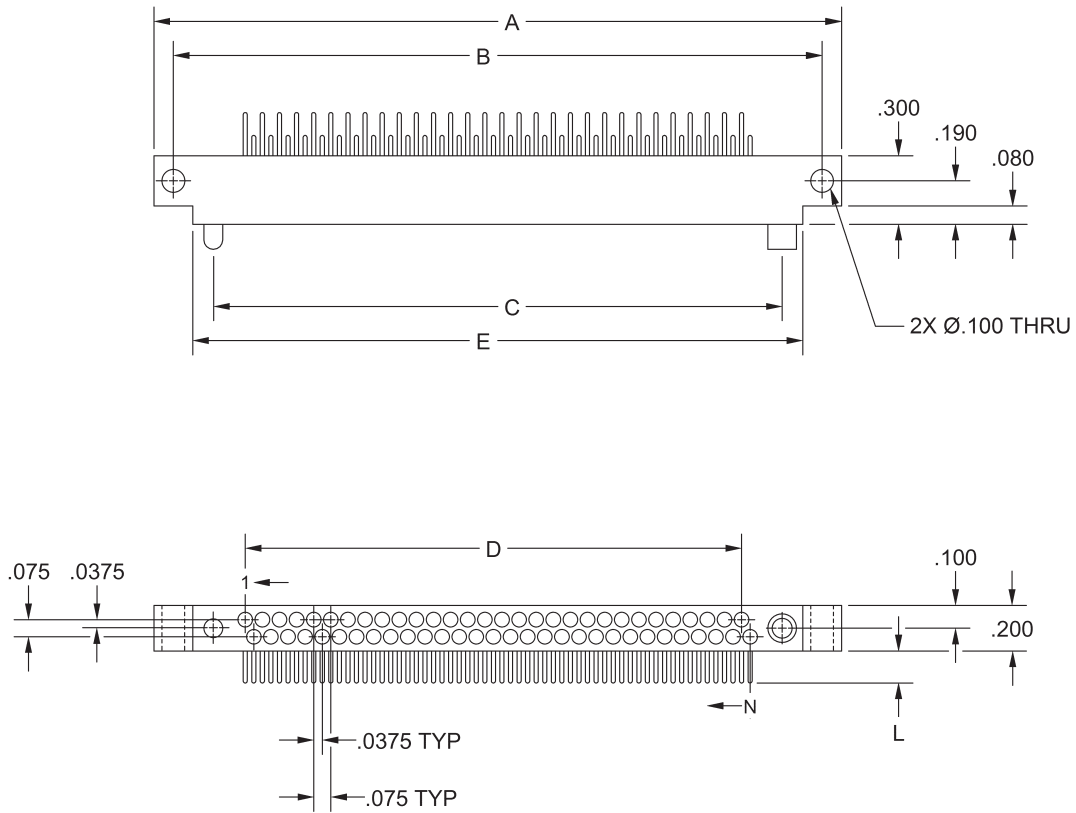

DIMENSIONS					
'N' Contacts	A	B	C	D	E
010	1.138	.968	.618	.300	.798
020	1.513	1.343	.993	.675	1.173
030	1.888	1.718	1.368	1.050	1.548
040	2.263	2.093	1.743	1.425	1.923
050	2.638	2.468	2.118	1.800	2.298
060	3.013	2.843	2.493	2.175	2.673
070	3.388	3.218	2.868	2.550	3.048
080	3.763	3.593	3.243	2.925	3.423
090	4.138	3.968	3.618	3.300	3.798
100	4.513	4.343	3.993	3.675	4.173

**REFER TO APPENDIX FOR TERMINATION
DETAILS, HARDWARE STYLES, POLAR-
IZATION CHART, MOUNTING STYLES,
VARIATION CODES, AND PWB PATTERNS**

**RECEPTACLE, SURFACE MOUNT
STYLE FRE**

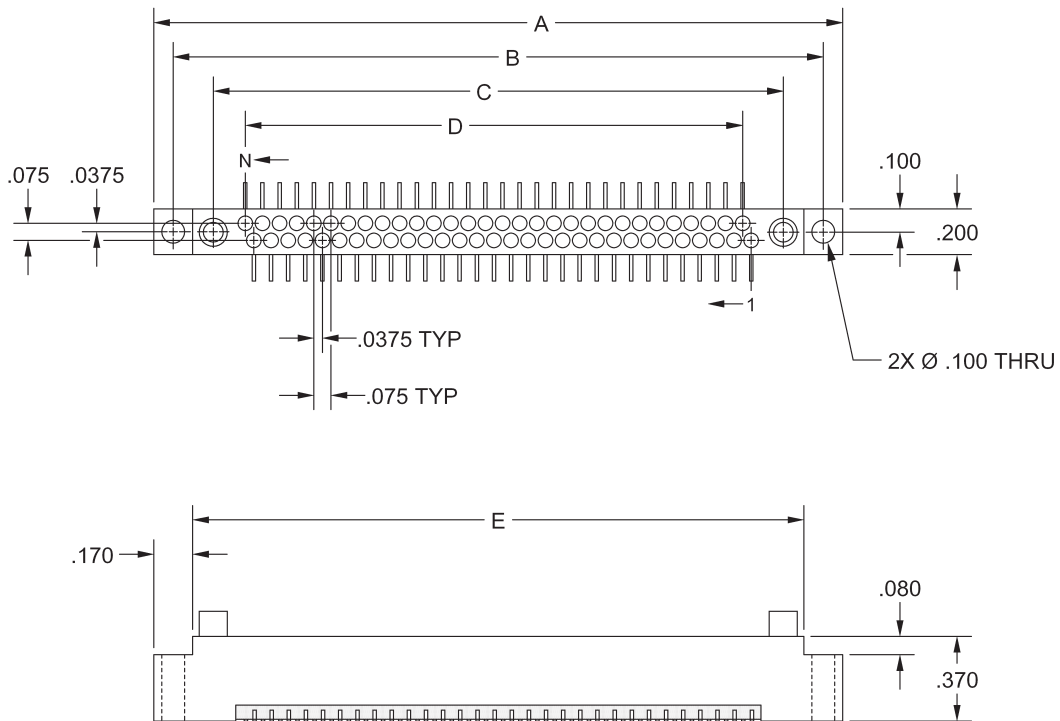

DIMENSIONS					
'N' Contacts	A	B	C	D	E
010	1.138	.968	.618	.300	.798
020	1.513	1.343	.993	.675	1.173
030	1.888	1.718	1.368	1.050	1.548
040	2.263	2.093	1.743	1.425	1.923
050	2.638	2.468	2.118	1.800	2.298
060	3.013	2.843	2.493	2.175	2.673
070	3.388	3.218	2.868	2.550	3.048
080	3.763	3.593	3.243	2.925	3.423
090	4.138	3.968	3.618	3.300	3.798
100	4.513	4.343	3.993	3.675	4.173

**REFER TO APPENDIX FOR TERMINATION
DETAILS, HARDWARE STYLES, POLAR-
IZATION CHART, MOUNTING STYLES,
VARIATION CODES, AND PWB PATTERNS**

PLUG, STACKING STYLE RAE

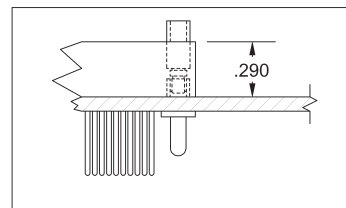
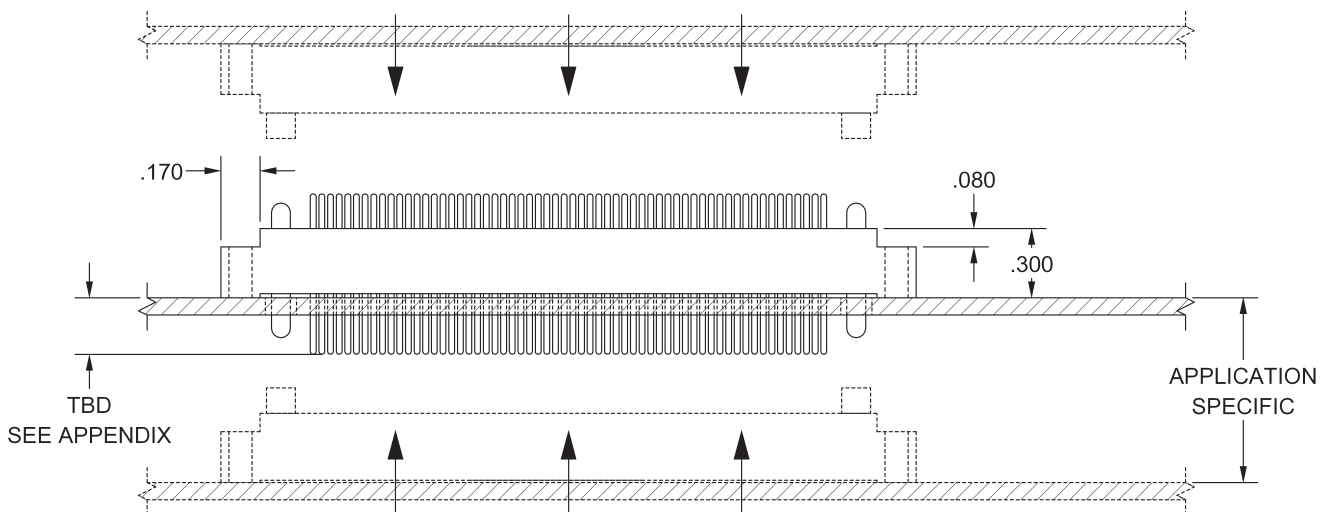
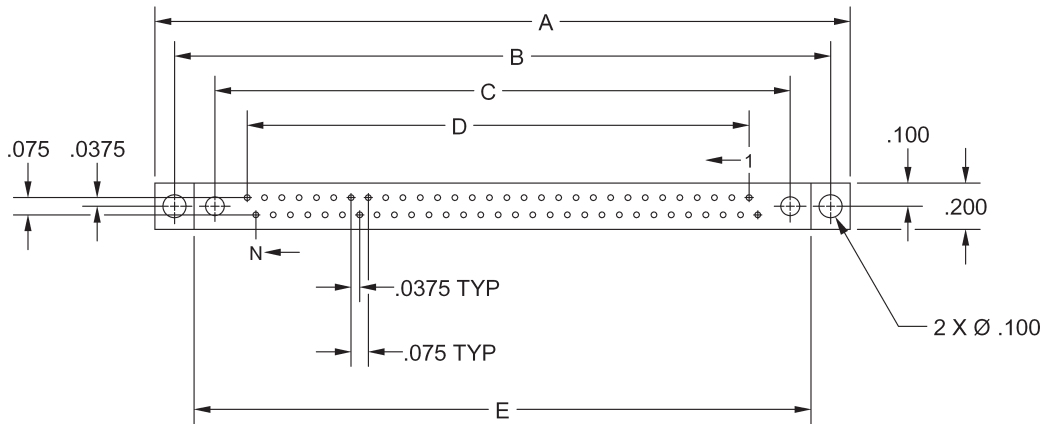

ALTERNATE PWB MOUNTING VIA
HARDWARE (MOUNTING EARS
REMOVED)

**REFER TO APPENDIX FOR TERMINATION
DETAILS, HARDWARE STYLES, POLAR-
IZATION CHART, MOUNTING STYLES,
VARIATION CODES, AND PWB PATTERNS**

DIMENSIONS					
'N' Contacts	A	B	C	D	E
010	1.138	.968	.618	.300	.798
020	1.513	1.343	.993	.675	1.173
030	1.888	1.718	1.368	1.050	1.548
040	2.263	2.093	1.743	1.425	1.923
050	2.638	2.468	2.118	1.800	2.298
060	3.013	2.843	2.493	2.175	2.673
070	3.388	3.218	2.868	2.550	3.048
080	3.763	3.593	3.243	2.925	3.423
090	4.138	3.968	3.618	3.300	3.798
100	4.513	4.343	3.993	3.675	4.173

PLUG, STRAIGHT
STYLE RBE, RDE, RSE, RVE, RWE

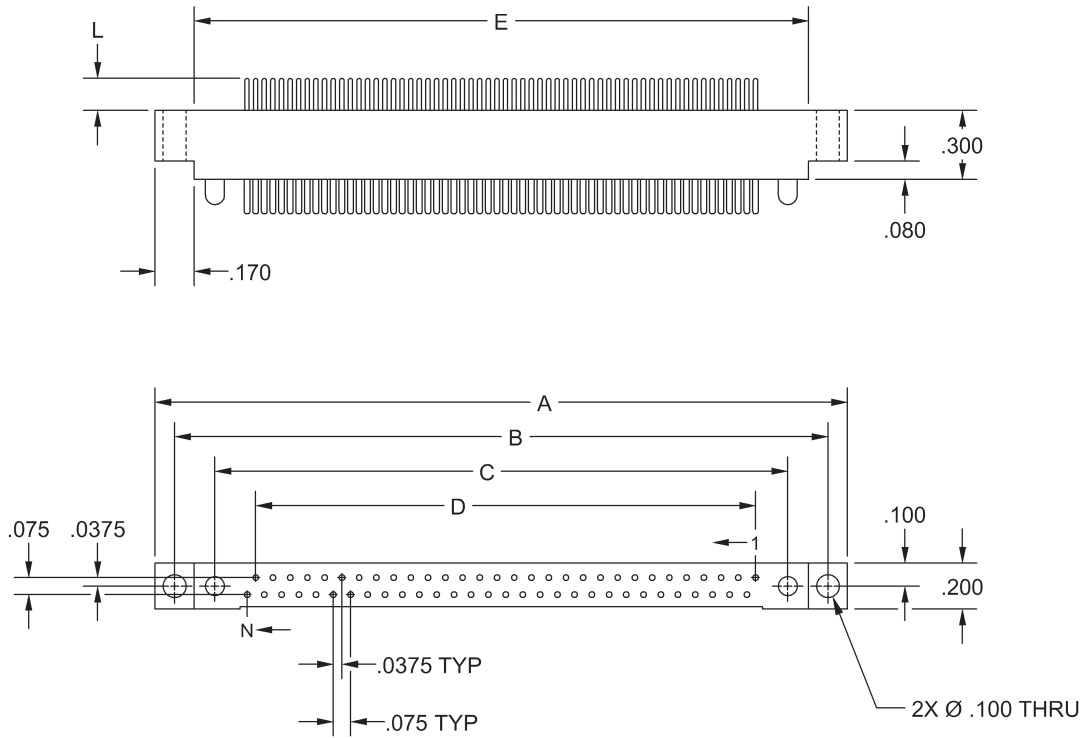

DIMENSIONS					
'N' Contacts	A	B	C	D	E
010	1.138	.968	.618	.300	.798
020	1.513	1.343	.993	.675	1.173
030	1.888	1.718	1.368	1.050	1.548
040	2.263	2.093	1.743	1.425	1.923
050	2.638	2.468	2.118	1.800	2.298
060	3.013	2.843	2.493	2.175	2.673
070	3.388	3.218	2.868	2.550	3.048
080	3.763	3.593	3.243	2.925	3.423
090	4.138	3.968	3.618	3.300	3.798
100	4.513	4.343	3.993	3.675	4.173

**REFER TO APPENDIX FOR TERMINATION
 DETAILS, HARDWARE STYLES, POLAR-
 IZATION CHART, MOUNTING STYLES,
 VARIATION CODES, AND PWB PATTERNS**

PLUG, RIGHT ANGLE STYLE MEE, MLE

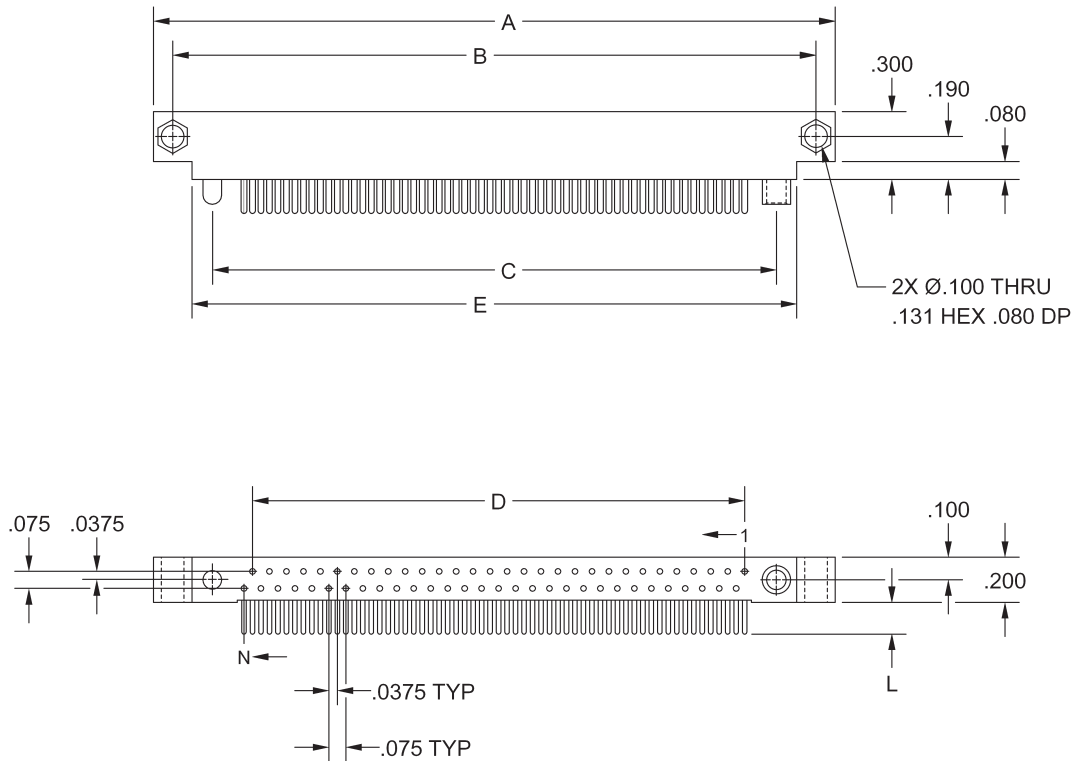

DIMENSIONS					
'N' Contacts	A	B	C	D	E
010	1.138	.968	.618	.300	.798
020	1.513	1.343	.993	.675	1.173
030	1.888	1.718	1.368	1.050	1.548
040	2.263	2.093	1.743	1.425	1.923
050	2.638	2.468	2.118	1.800	2.298
060	3.013	2.843	2.493	2.175	2.673
070	3.388	3.218	2.868	2.550	3.048
080	3.763	3.593	3.243	2.925	3.423
090	4.138	3.968	3.618	3.300	3.798
100	4.513	4.343	3.993	3.675	4.173

**REFER TO APPENDIX FOR TERMINATION
DETAILS, HARDWARE STYLES, POLAR-
IZATION CHART, MOUNTING STYLES,
VARIATION CODES, AND PWB PATTERNS**

**PLUG, SURFACE MOUNT
STYLE MRE**

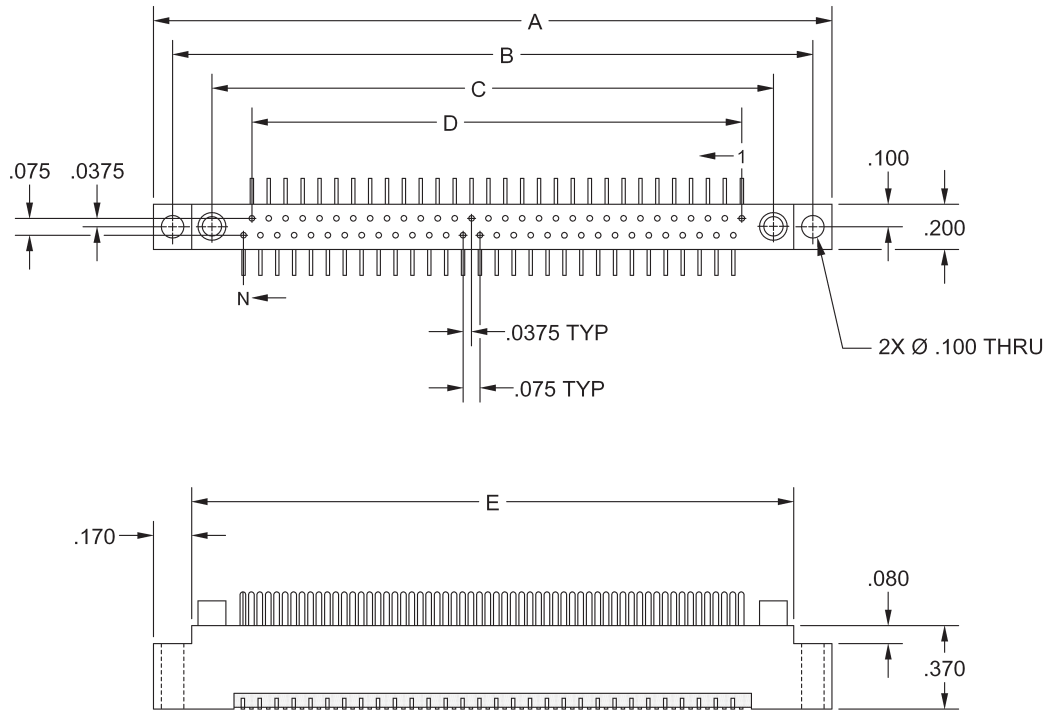

DIMENSIONS					
'N' Contacts	A	B	C	D	E
010	1.138	.968	.618	.300	.798
020	1.513	1.343	.993	.675	1.173
030	1.888	1.718	1.368	1.050	1.548
040	2.263	2.093	1.743	1.425	1.923
050	2.638	2.468	2.118	1.800	2.298
060	3.013	2.843	2.493	2.175	2.673
070	3.388	3.218	2.868	2.550	3.048
080	3.763	3.593	3.243	2.925	3.423
090	4.138	3.968	3.618	3.300	3.798
100	4.513	4.343	3.993	3.675	4.173

**REFER TO APPENDIX FOR TERMINATION
DETAILS, HARDWARE STYLES, POLAR-
IZATION CHART, MOUNTING STYLES,
VARIATION CODES, AND PWB PATTERNS**

ORDERING CHART .075 X .075 SPACING

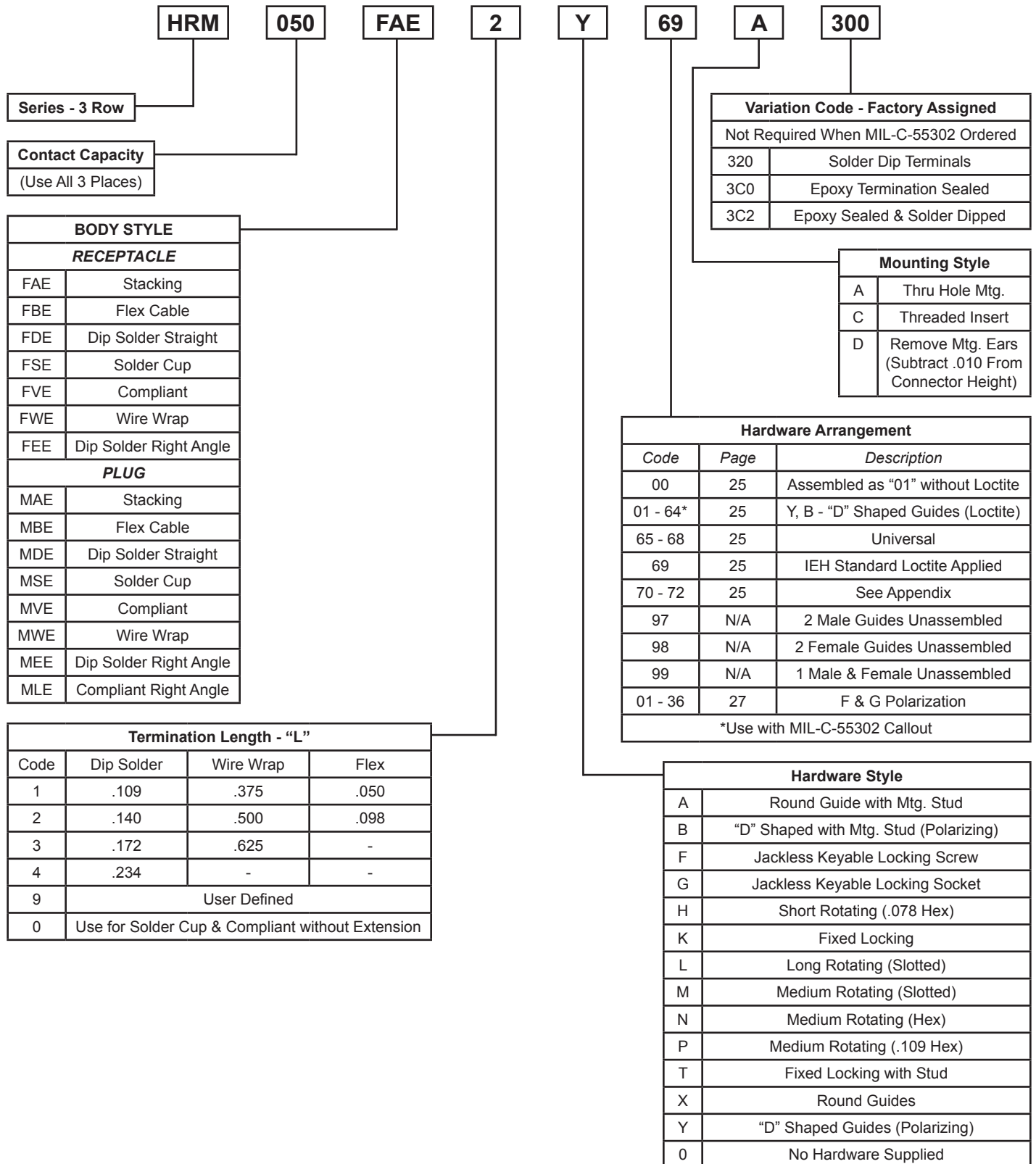

Series - 3 Row

Contact Capacity
(Use All 3 Places)

BODY STYLE	
RECEPTACLE	
FAE	Stacking
FBE	Flex Cable
FDE	Dip Solder Straight
FSE	Solder Cup
FVE	Compliant
FWE	Wire Wrap
FEE	Dip Solder Right Angle
PLUG	
MAE	Stacking
MBE	Flex Cable
MDE	Dip Solder Straight
MSE	Solder Cup
MVE	Compliant
MWE	Wire Wrap
MEE	Dip Solder Right Angle
MLE	Compliant Right Angle

Termination Length - "L"			
Code	Dip Solder	Wire Wrap	Flex
1	.109	.375	.050
2	.140	.500	.098
3	.172	.625	-
4	.234	-	-
9	User Defined		
0	Use for Solder Cup & Compliant without Extension		

Variation Code - Factory Assigned	
Not Required When MIL-C-55302 Ordered	
320	Solder Dip Terminals
3C0	Epoxy Termination Sealed
3C2	Epoxy Sealed & Solder Dipped

Mounting Style	
A	Thru Hole Mtg.
C	Threaded Insert
D	Remove Mtg. Ears (Subtract .010 From Connector Height)

Hardware Arrangement		
Code	Page	Description
00	25	Assembled as "01" without Loctite
01 - 64*	25	Y, B - "D" Shaped Guides (Loctite)
65 - 68	25	Universal
69	25	IEH Standard Loctite Applied
70 - 72	25	See Appendix
97	N/A	2 Male Guides Unassembled
98	N/A	2 Female Guides Unassembled
99	N/A	1 Male & Female Unassembled
01 - 36	27	F & G Polarization

*Use with MIL-C-55302 Callout

Hardware Style	
A	Round Guide with Mtg. Stud
B	"D" Shaped with Mtg. Stud (Polarizing)
F	Jackless Keyable Locking Screw
G	Jackless Keyable Locking Socket
H	Short Rotating (.078 Hex)
K	Fixed Locking
L	Long Rotating (Slotted)
M	Medium Rotating (Slotted)
N	Medium Rotating (Hex)
P	Medium Rotating (.109 Hex)
T	Fixed Locking with Stud
X	Round Guides
Y	"D" Shaped Guides (Polarizing)
0	No Hardware Supplied

RECEPTACLE, STACKING STYLE FAE

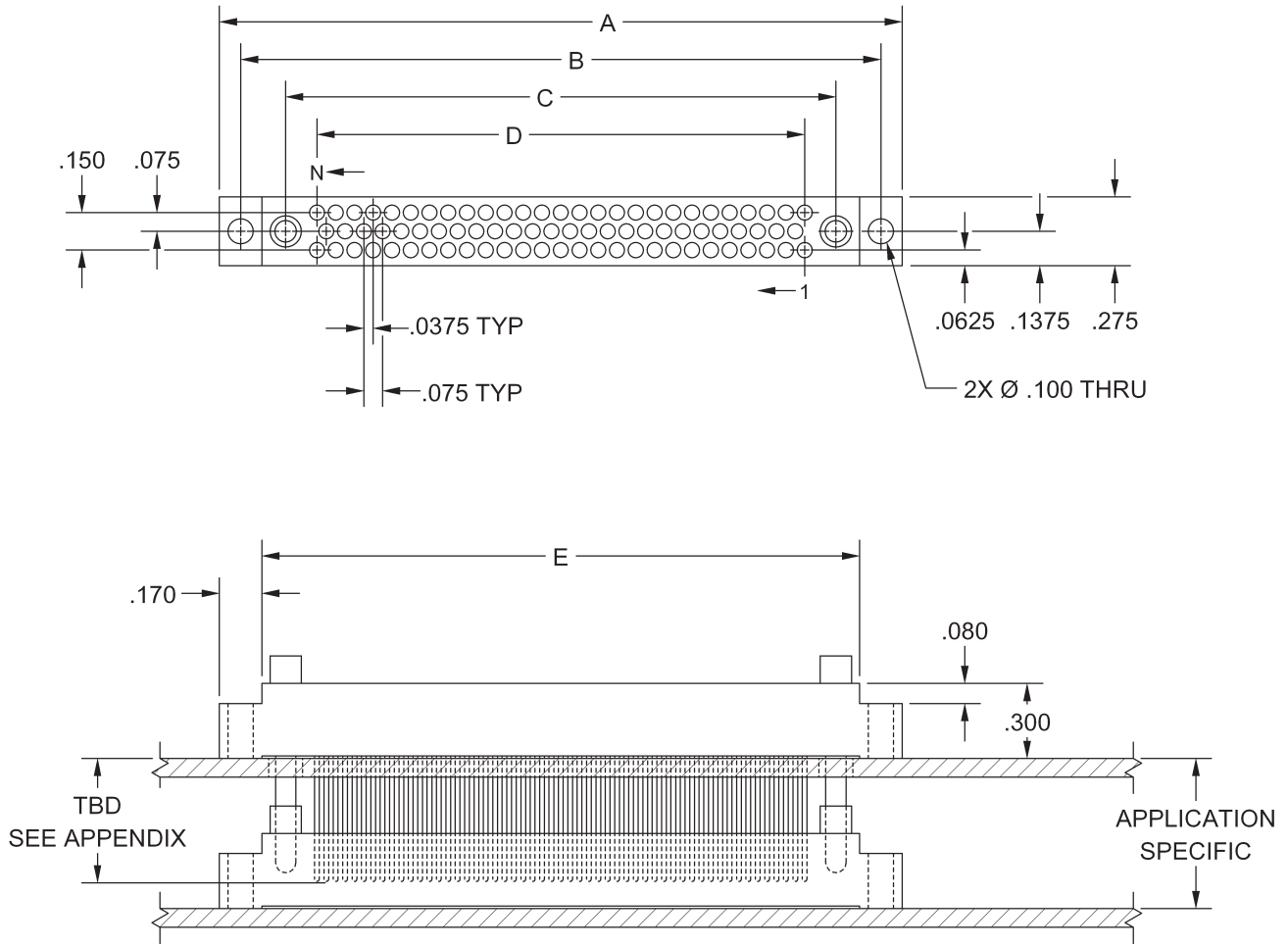

'N' Contacts	DIMENSIONS				
	A	B	C	D	E
011	1.005	.835	.475	.225	.665
023	1.305	1.135	.775	.525	.965
035	1.605	1.435	1.075	.825	1.265
047	1.905	1.735	1.375	1.125	1.565
059	2.205	2.035	1.675	1.425	1.865
071	2.505	2.335	1.975	1.725	2.165
080	2.730	2.560	2.200	1.950	2.390
089	2.955	2.785	2.425	2.175	2.615
092	3.030	2.860	2.500	2.250	2.690
104	3.330	3.160	2.800	2.55	2.990
122	3.780	3.610	3.250	3.000	3.440
152	4.530	4.360	4.000	3.750	4.190
206	5.880	5.710	5.350	5.100	5.540

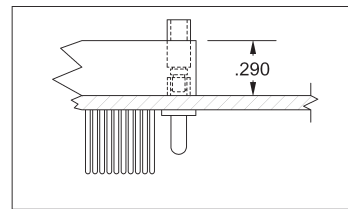

ALTERNATE PWB MOUNTING VIA
HARDWARE (MOUNTING EARS
REMOVED)

**REFER TO APPENDIX FOR TERMINATION
DETAILS, HARDWARE STYLES, POLAR-
IZATION CHART, MOUNTING STYLES,
VARIATION CODES, AND PWB PATTERNS**

RECEPTACLE, STRAIGHT STYLE FBE, FDE, FSE, FVE, FWE

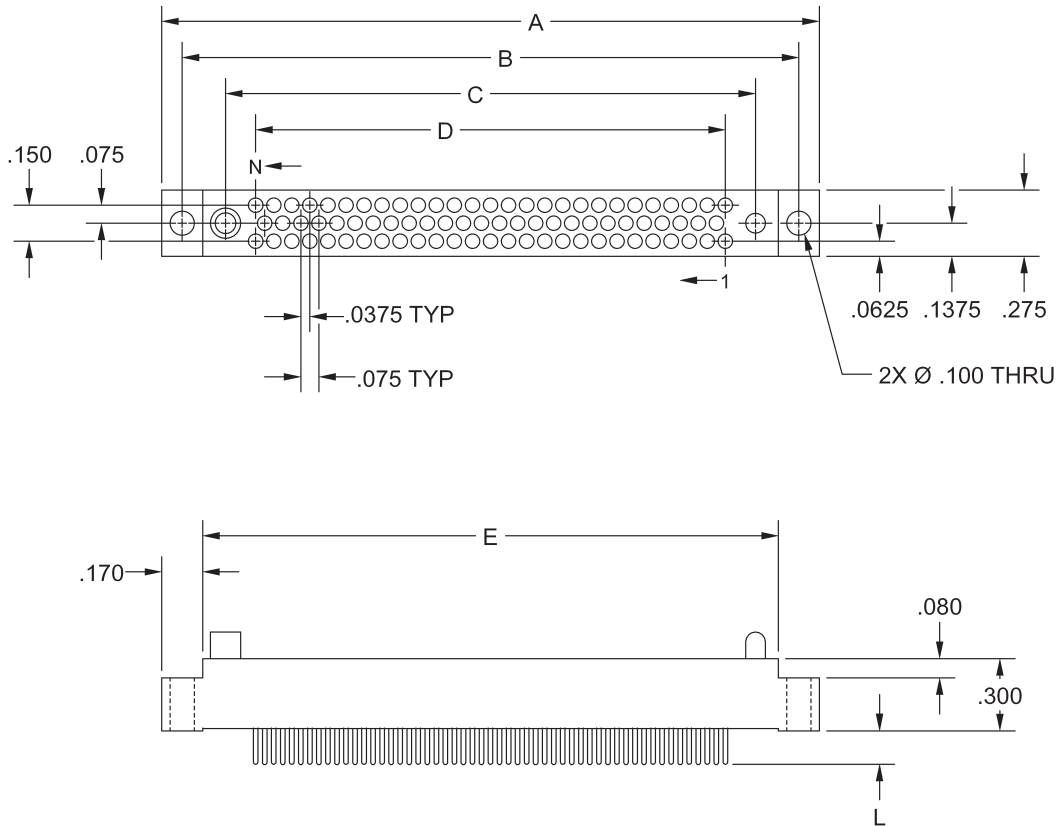

'N' Contacts	DIMENSIONS				
	A	B	C	D	E
011	1.005	.835	.475	.225	.665
023	1.305	1.135	.775	.525	.965
035	1.605	1.435	1.075	.825	1.265
047	1.905	1.735	1.375	1.125	1.565
059	2.205	2.035	1.675	1.425	1.865
071	2.505	2.335	1.975	1.725	2.165
080	2.730	2.560	2.200	1.950	2.390
089	2.955	2.785	2.425	2.175	2.615
092	3.030	2.860	2.500	2.250	2.690
104	3.330	3.160	2.800	2.55	2.990
122	3.780	3.610	3.250	3.000	3.440
152	4.530	4.360	4.000	3.750	4.190
206	5.880	5.710	5.350	5.100	5.540

**REFER TO APPENDIX FOR TERMINATION
DETAILS, HARDWARE STYLES, POLAR-
IZATION CHART, MOUNTING STYLES,
VARIATION CODES, AND PWB PATTERNS**

**RECEPTACLE, RIGHT ANGLE
STYLE FEE**

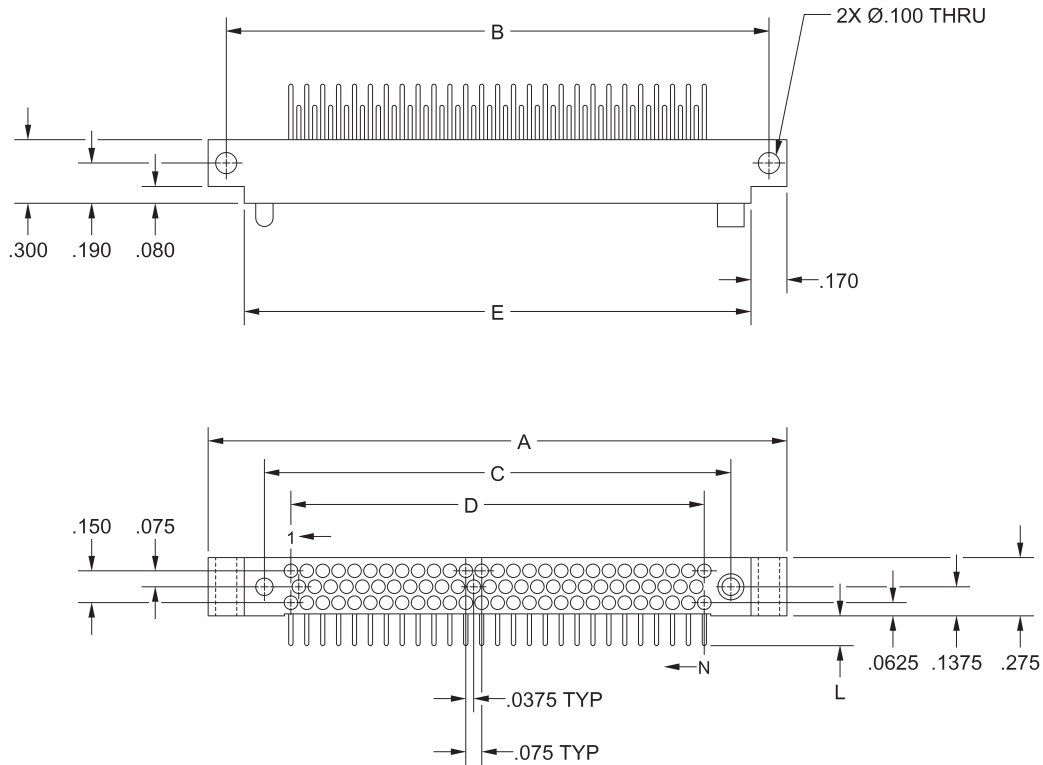

'N' Contacts	DIMENSIONS				
	A	B	C	D	E
011	1.005	.835	.475	.225	.665
023	1.305	1.135	.775	.525	.965
035	1.605	1.435	1.075	.825	1.265
047	1.905	1.735	1.375	1.125	1.565
059	2.205	2.035	1.675	1.425	1.865
071	2.505	2.335	1.975	1.725	2.165
080	2.730	2.560	2.200	1.950	2.390
089	2.955	2.785	2.425	2.175	2.615
092	3.030	2.860	2.500	2.250	2.690
104	3.330	3.160	2.800	2.55	2.990
122	3.780	3.610	3.250	3.000	3.440
152	4.530	4.360	4.000	3.750	4.190
206	5.880	5.710	5.350	5.100	5.540

**REFER TO APPENDIX FOR TERMINATION
DETAILS, HARDWARE STYLES, POLAR-
IZATION CHART, MOUNTING STYLES,
VARIATION CODES, AND PWB PATTERNS**

PLUG, STACKING STYLE MAE

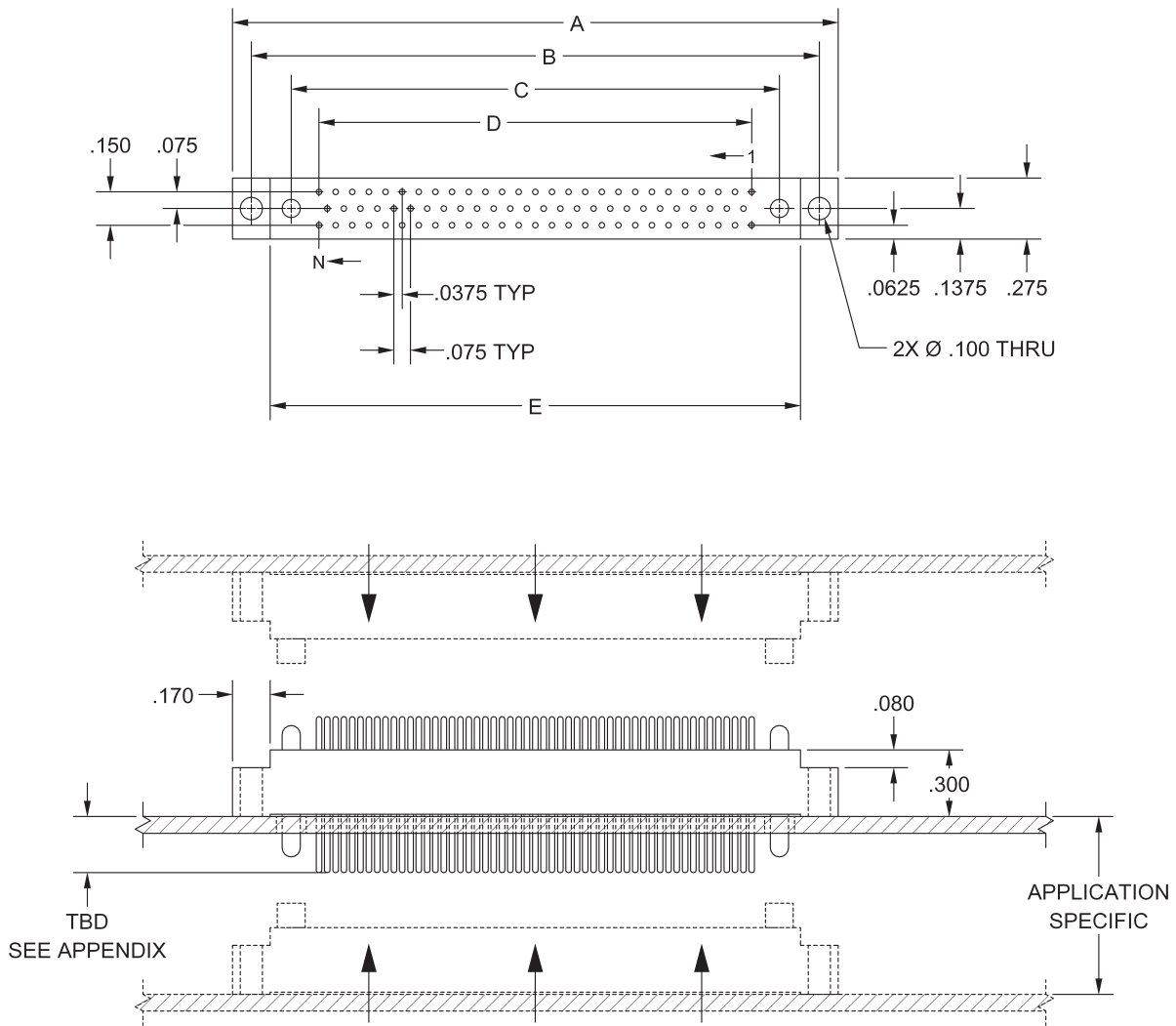

'N' Contacts	DIMENSIONS				
	A	B	C	D	E
011	1.005	.835	.475	.225	.665
023	1.305	1.135	.775	.525	.965
035	1.605	1.435	1.075	.825	1.265
047	1.905	1.735	1.375	1.125	1.565
059	2.205	2.035	1.675	1.425	1.865
071	2.505	2.335	1.975	1.725	2.165
080	2.730	2.560	2.200	1.950	2.390
089	2.955	2.785	2.425	2.175	2.615
092	3.030	2.860	2.500	2.250	2.690
104	3.330	3.160	2.800	2.55	2.990
122	3.780	3.610	3.250	3.000	3.440
152	4.530	4.360	4.000	3.750	4.190
206	5.880	5.710	5.350	5.100	5.540

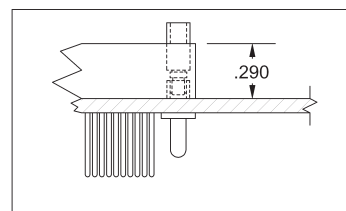

ALTERNATE PWB MOUNTING VIA
HARDWARE (MOUNTING EARS
REMOVED)

**REFER TO APPENDIX FOR TERMINATION
DETAILS, HARDWARE STYLES, POLAR-
IZATION CHART, MOUNTING STYLES,
VARIATION CODES, AND PWB PATTERNS**

**PLUG, STRAIGHT
STYLE MBE, MDE, MSE, MVE, MWE**

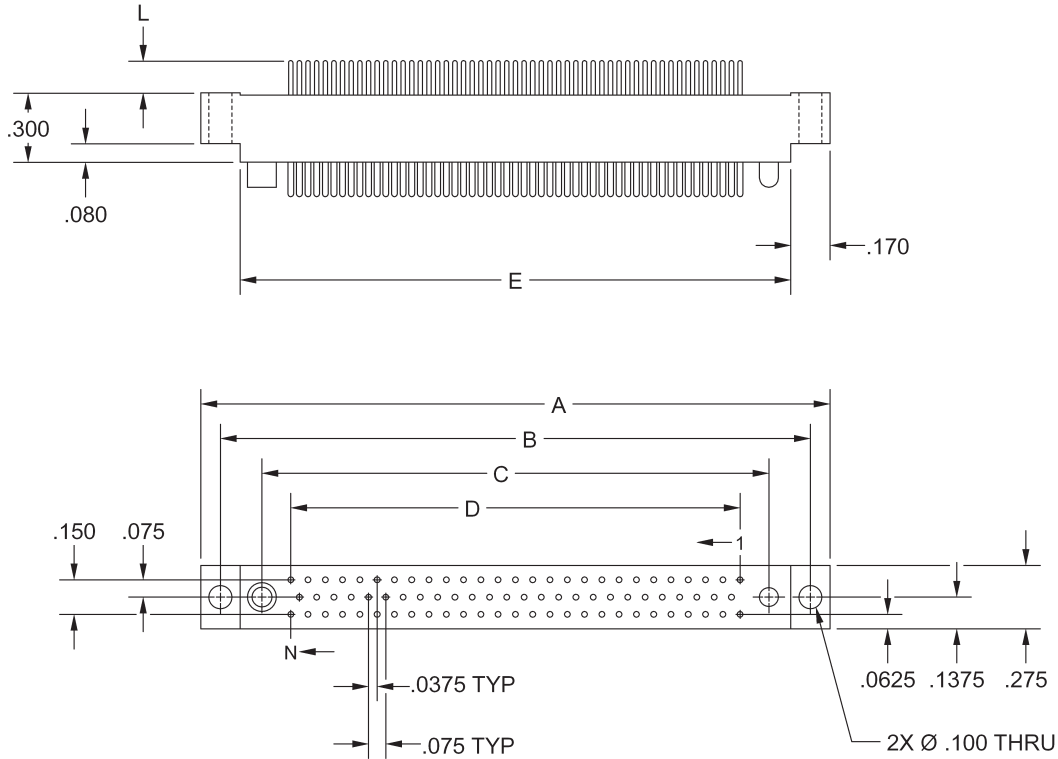

'N' Contacts	DIMENSIONS				
	A	B	C	D	E
011	1.005	.835	.475	.225	.665
023	1.305	1.135	.775	.525	.965
035	1.605	1.435	1.075	.825	1.265
047	1.905	1.735	1.375	1.125	1.565
059	2.205	2.035	1.675	1.425	1.865
071	2.505	2.335	1.975	1.725	2.165
080	2.730	2.560	2.200	1.950	2.390
089	2.955	2.785	2.425	2.175	2.615
092	3.030	2.860	2.500	2.250	2.690
104	3.330	3.160	2.800	2.55	2.990
122	3.780	3.610	3.250	3.000	3.440
152	4.530	4.360	4.000	3.750	4.190
206	5.880	5.710	5.350	5.100	5.540

**REFER TO APPENDIX FOR TERMINATION
DETAILS, HARDWARE STYLES, POLAR-
IZATION CHART, MOUNTING STYLES,
VARIATION CODES, AND PWB PATTERNS**

PLUG, RIGHT ANGLE STYLE MEE, MLE

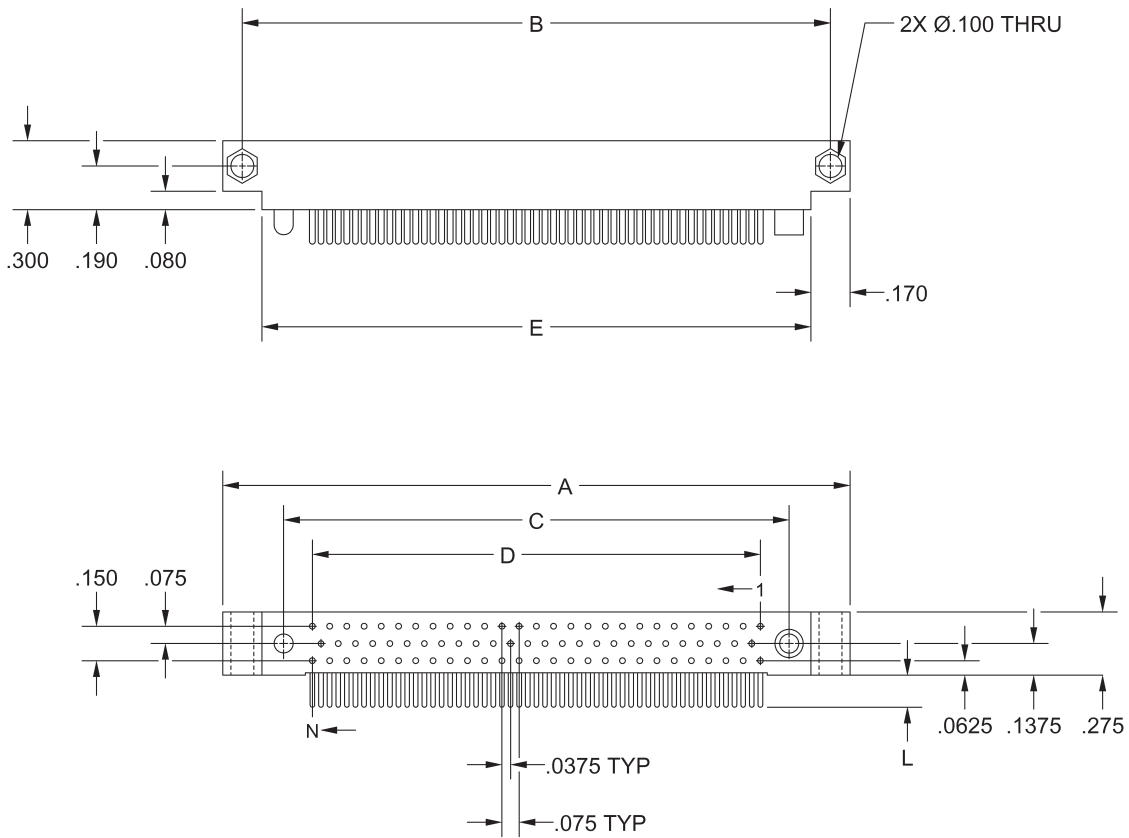

DIMENSIONS					
'N' Contacts	A	B	C	D	E
011	1.005	.835	.475	.225	.665
023	1.305	1.135	.775	.525	.965
035	1.605	1.435	1.075	.825	1.265
047	1.905	1.735	1.375	1.125	1.565
059	2.205	2.035	1.675	1.425	1.865
071	2.505	2.335	1.975	1.725	2.165
080	2.730	2.560	2.200	1.950	2.390
089	2.955	2.785	2.425	2.175	2.615
092	3.030	2.860	2.500	2.250	2.690
104	3.330	3.160	2.800	2.55	2.990
122	3.780	3.610	3.250	3.000	3.440
152	4.530	4.360	4.000	3.750	4.190
206	5.880	5.710	5.350	5.100	5.540

**REFER TO APPENDIX FOR TERMINATION
 DETAILS, HARDWARE STYLES, POLAR-
 IZATION CHART, MOUNTING STYLES,
 VARIATION CODES, AND PWB PATTERNS**

TERMINATION STYLE - 2 ROW RECEPTACLE CONTACTS

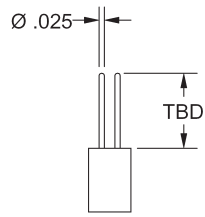

FAE
STACKING
Termination Length
is Application Specific

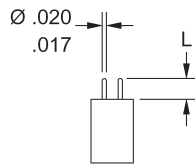

FBE
FLEX CABLE
'L'
1 = .050
2 = .098

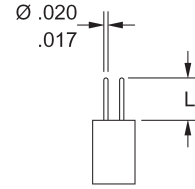

FDE
DIP SOLDER STRAIGHT
'L'
1 = .109
2 = .140
3 = .172
4 = .234
9 = User Defined

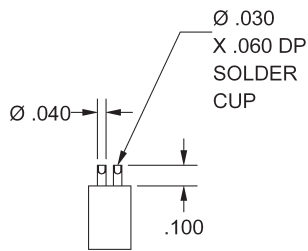

FSE0
SOLDER CUP

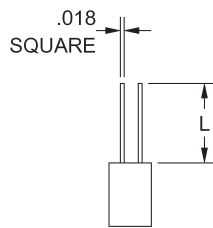

FWE
WIRE WRAP
'L'
1 = .375
2 = .500
3 = .625

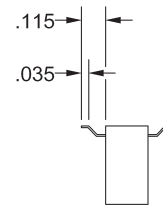

FRE9
SURFACE MOUNT

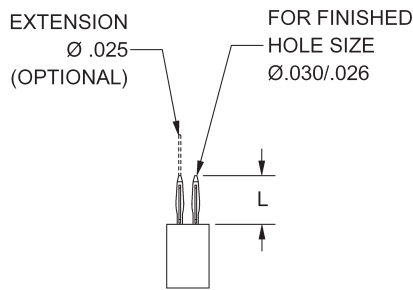

FVE
COMPLIANT
'L'
0 = Std .230
A = User Defined
Extension
(Compliant Stacking)

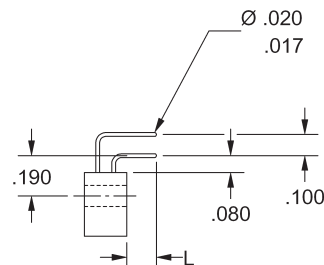

FEE
DIP SOLDER RIGHT ANGLE
'L'
1 = .109
2 = .140
3 = .172
4 = .234
9 = User Defined

TERMINATION STYLE - 2 ROW PLUG CONTACTS

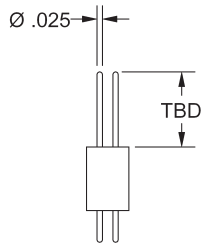

RAE
STACKING
Termination Length
is Application Specific

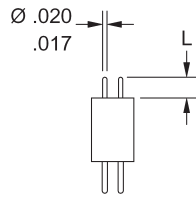

RBE
FLEX CABLE
'L'
1 = .050
2 = .098

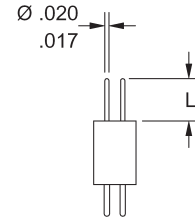

RDE
DIP SOLDER STRAIGHT
'L'
1 = .109
2 = .140
3 = .172
4 = .234
9 = User Defined

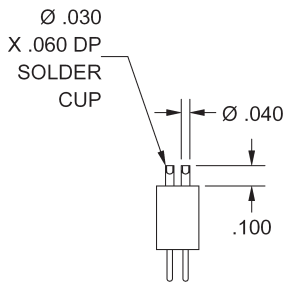

RSE0
SOLDER CUP

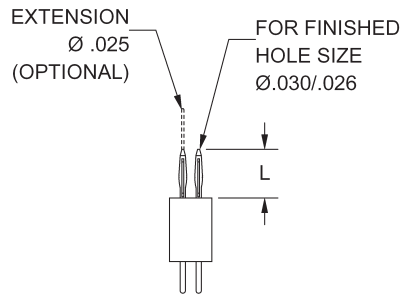

RVE
COMPLIANT
'L'
0 = Std .230
A = User Defined
Extension
(Compliant Stacking)

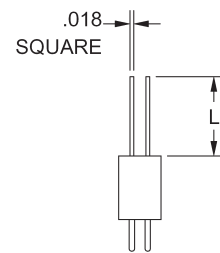

RWE
WIRE WRAP
'L'
1 = .375
2 = .500
3 = .625

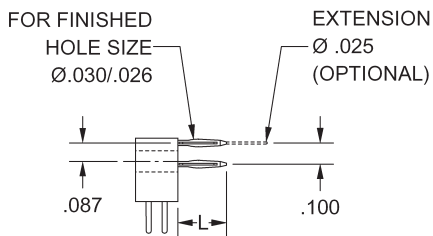

MLE
RIGHT ANGLE COMPLIANT
'L'
0 = Std .230
A = User Defined
Extension
(Compliant Stacking)

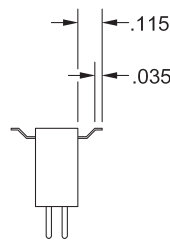

MRE9
SURFACE MOUNT

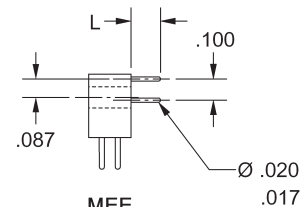

MEE
DIP SOLDER RIGHT ANGLE
'L'
1 = .109
2 = .140
3 = .172
4 = .234
9 = User Defined

TERMINATION STYLE - 3 ROW RECEPTACLE CONTACTS

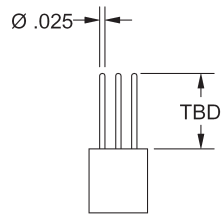

FAE
STACKING
Termination Length
is Application Specific

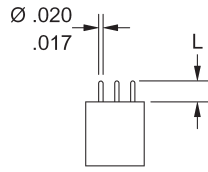

FBE
FLEX CABLE
'L'
1 = .050
2 = .098

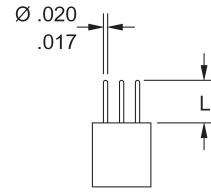

FDE
DIP SOLDER STRAIGHT
'L'
1 = .109
2 = .140
3 = .172
4 = .234
9 = User Defined

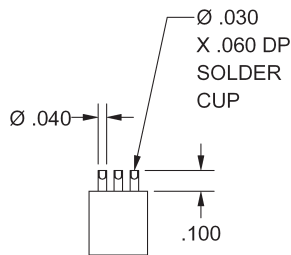

FSE0
SOLDER CUP

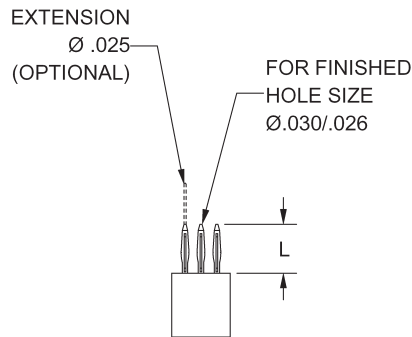

FVE
COMPLIANT
'L'
0 = Std .230
A = User Defined
Extension
(Compliant Stacking)

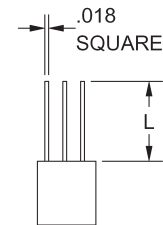

FWE
WIRE WRAP
'L'
1 = .375
2 = .500
3 = .625

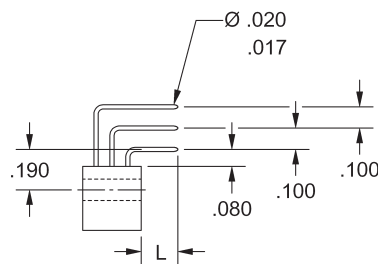

FEE
DIP SOLDER RIGHT ANGLE
'L'
1 = .109
2 = .140
3 = .172
4 = .234
9 = User Defined

TERMINATION STYLE - 3 ROW PLUG CONTACTS

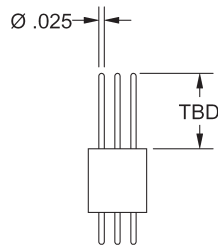

MAE
STACKING
Termination Length
is Application
Dependent

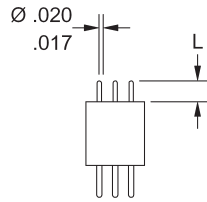

MBE
FLEX CABLE
'L'
1 = .050
2 = .098

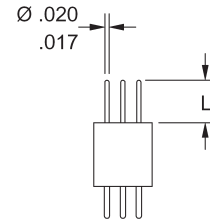

MDE
DIP SOLDER STRAIGHT
'L'
1 = .109
2 = .140
3 = .172
4 = .234
9 = User Defined

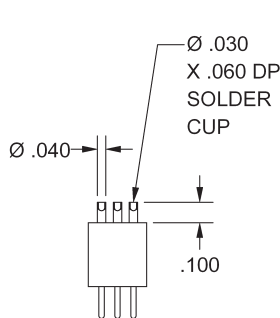

MSE0
SOLDER CUP

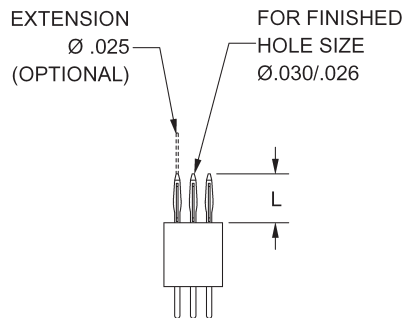

MVE
COMPLIANT
'L'
0 = Std .230
A = User Defined
Extension
(Compliant Stacking)

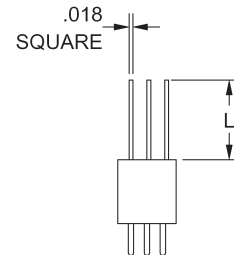

MWE
WIRE WRAP
'L'
1 = .375
2 = .500
3 = .625

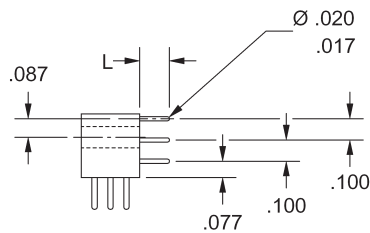

MEE
DIP SOLDER RIGHT ANGLE
'L'
1 = .109
2 = .140
3 = .172
4 = .234
9 = User Defined

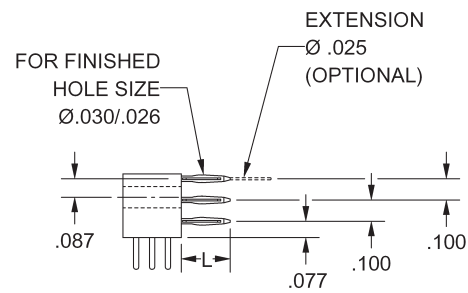

MLE
COMPLIANT
'L'
0 = Std .230
A = User Defined
Extension
(Compliant Stacking)

HARDWARE STYLE

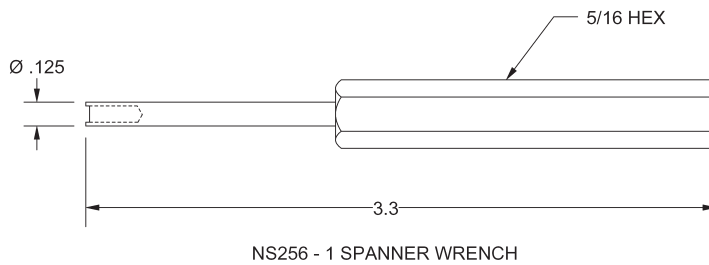
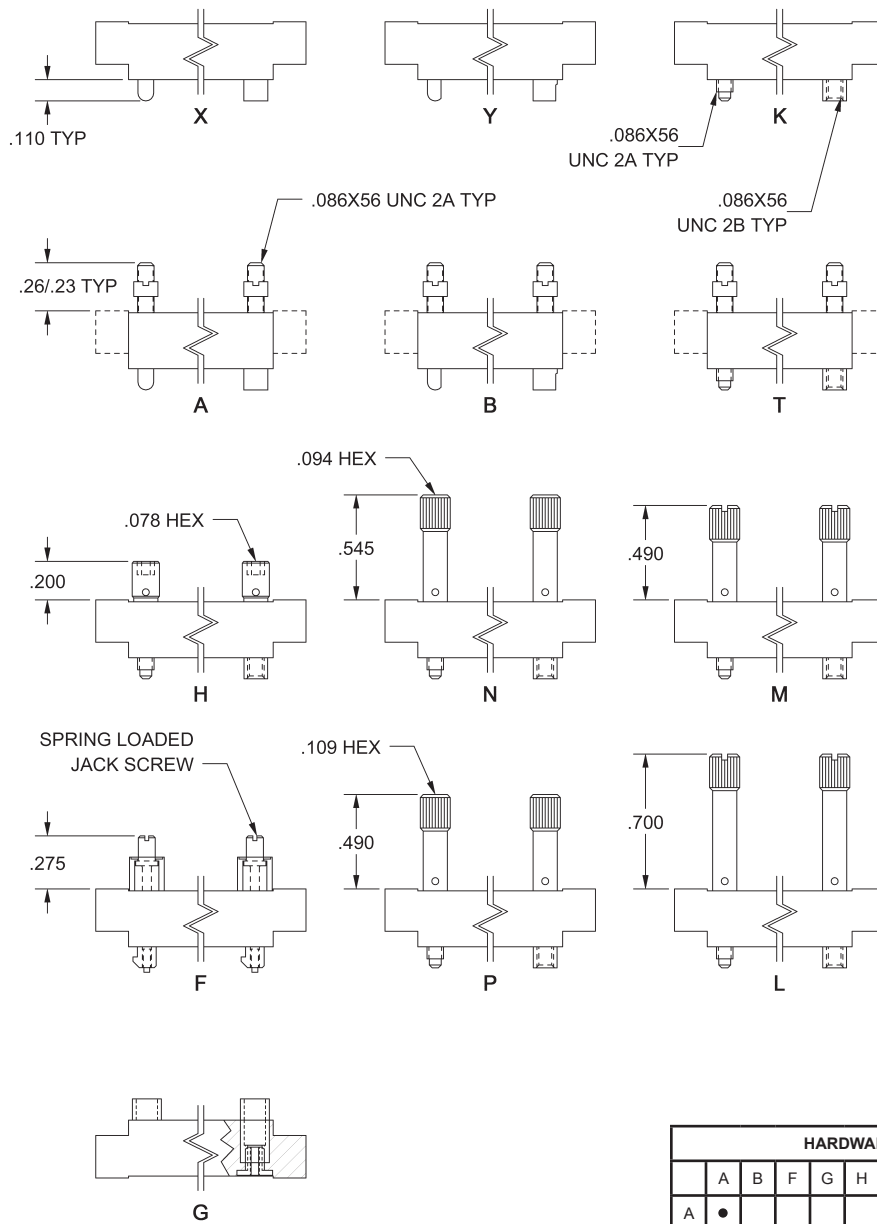

HARDWARE COMPATIBILITY													
	A	B	F	G	H	K	L	M	N	P	T	X	Y
A	•											•	
B		•											•
F			•										
G		•											
H					•						•		
K					•	•	•	•	•	•			
L					•						•		
M					•						•		
N					•						•		
P					•						•		
T					•		•	•	•	•			
X	•											•	
Y		•											•

POLARIZATION CHART A, B, H, K, L, M, N, P, T, X, Y HARDWARE

AS VIEWED FROM THE MATING FACE

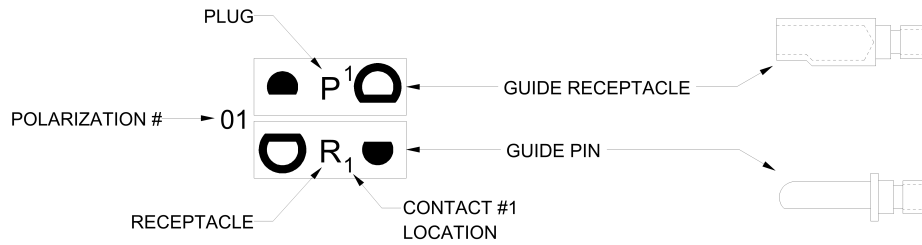

01 - 64 USE FOR HARDWARE STYLE 'Y' AND 'B'

01		09		17		25		33		41		49		57	
02		10		18		26		34		42		50		58	
03		11		19		27		35		43		51		59	
04		12		20		28		36		44		52		60	
05		13		21		29		37		45		53		61	
06		14		22		30		38		46		54		62	
07		15		23		31		39		47		55		63	
08		16		24		32		40		48		56		64	

UNIVERSAL TEST

USE FOR OPTION: A,H,K,L,M,N,P,T,X

65		66		67		68		69		70		71		72	
----	--	----	--	----	--	----	--	----	--	----	--	----	--	----	--

F & G HARDWARE DETAIL JACKLESS KEYABLE LOCKING

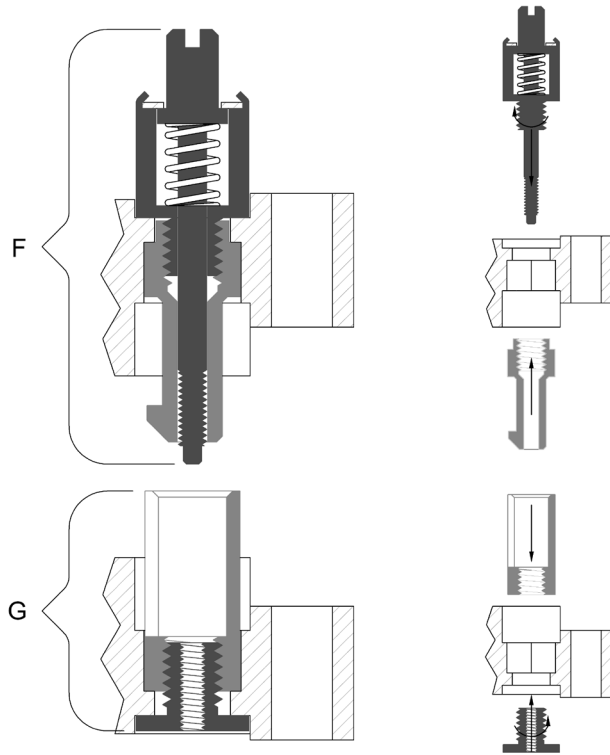

F & G Combines All of The Most Desirable Attributes of Proven Military Hardware.

JACKLESS - A new spring loaded jacket design allows the user to fully mate the connectors before screwing down the hardware. Most traditional designs do not allow a full mate, limiting the progress to 1 turn per screw per side, repeated until locked.

KEYABLE - The interlocking pieces incorporate a hex body with a fixed slot and key. 'F' hardware contains the key and 'G' hardware contains the slot. Both insulators for F and G employ a hex recess to accommodate up to 36 polarization options for 2 pairs (see details on following page).

LOCKING - For high stress and vibration environments, connectors are fully locked for uninterrupted operation.

F Hardware (Assembled)

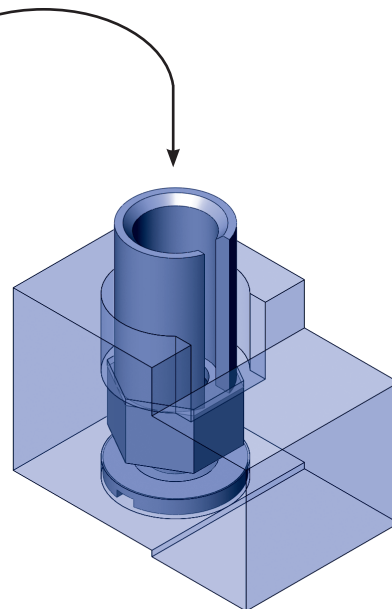
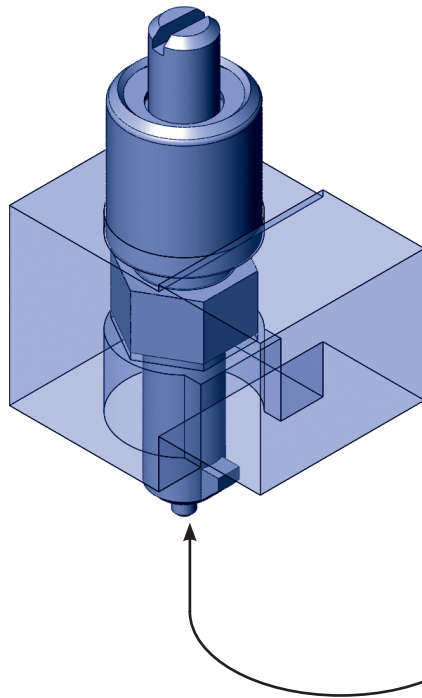

G Hardware (Assembled)

POLARIZATION CHART F & G HARDWARE (ONLY AVAILABLE ON 3 ROW CONNECTORS)

AS VIEWED FROM THE MATING FACE

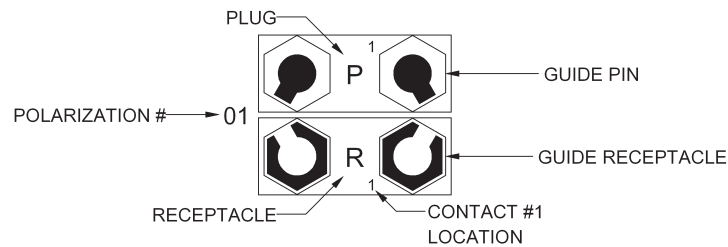

01		07		13		19		25		31	
02		08		14		20		26		32	
03		09		15		21		27		33	
04		10		16		22		28		34	
05		11		17		23		29		35	
06		12		18		24		30		36	

PWB PATTERNS

PLUG - DIP SOLDER & SURFACE MOUNT

ALL VIEWS ARE FROM COMPONENT SIDE

MEE 2-ROW
DIP SOLDER RIGHT ANGLE

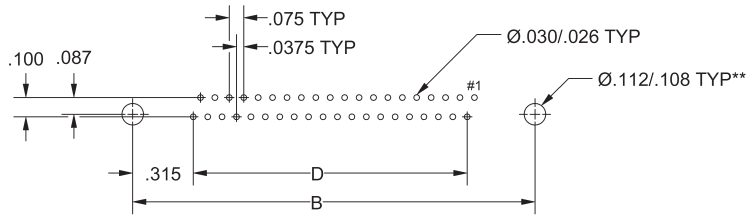

MEE 3-ROW
DIP SOLDER RIGHT ANGLE

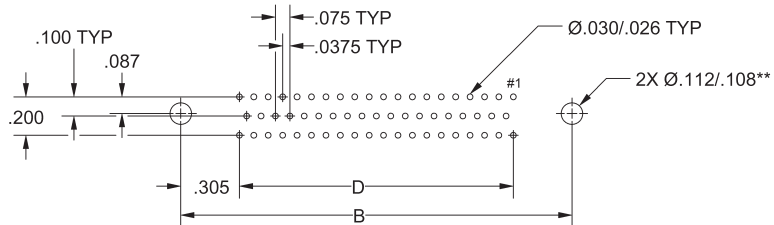

RDE 2-ROW
DIP SOLDER STRAIGHT
(RAE 2-ROW STACKING)

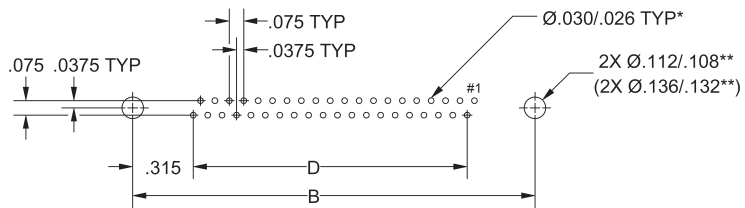

MDE 3-ROW
DIP SOLDER STRAIGHT
(MAE 3-ROW STACKING)

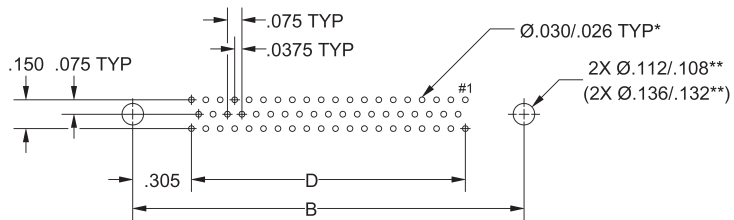

MRE 2-ROW
SURFACE MOUNT

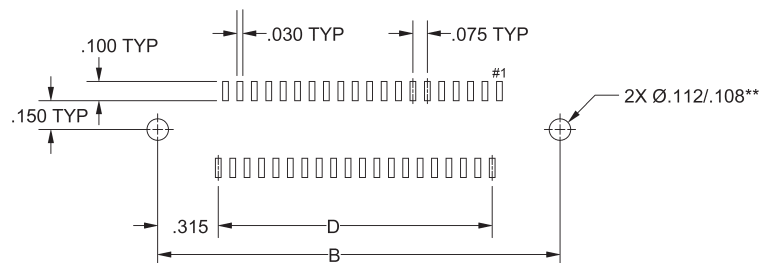

*REQUIRED HOLE SIZE FOR COMPLIANT TERMINATION STYLE CONTACTS. FOR ALL OTHERS, HOLE SIZE SUBJECT TO USER MODIFICATION FOR APPLICATION OR ALTERNATIVE STANDARDS.

**RECOMMENDATION. MAY BE MODIFIED FOR APPLICATION OR ALTERNATIVE STANDARDS.

PWB PATTERNS

RECEPTACLE - DIP SOLDER & SURFACE MOUNT

ALL VIEWS ARE FROM COMPONENT SIDE

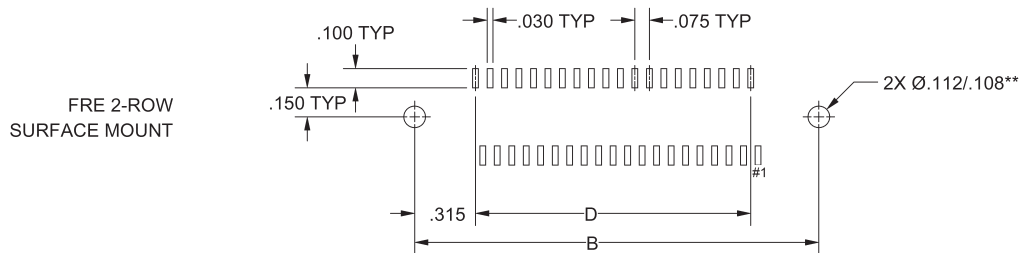
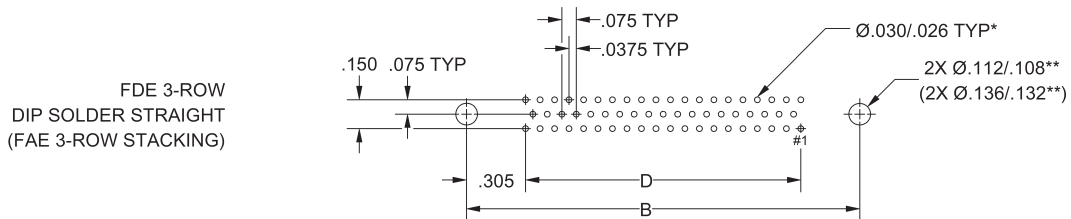
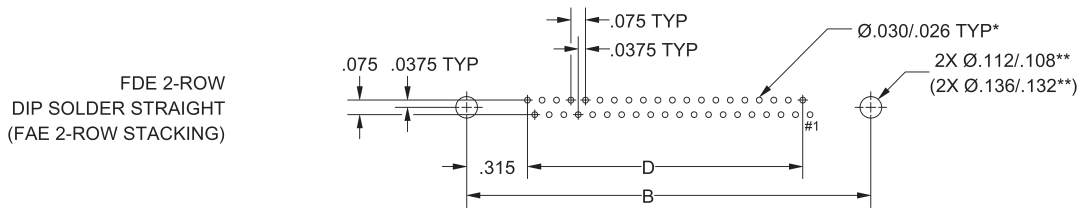
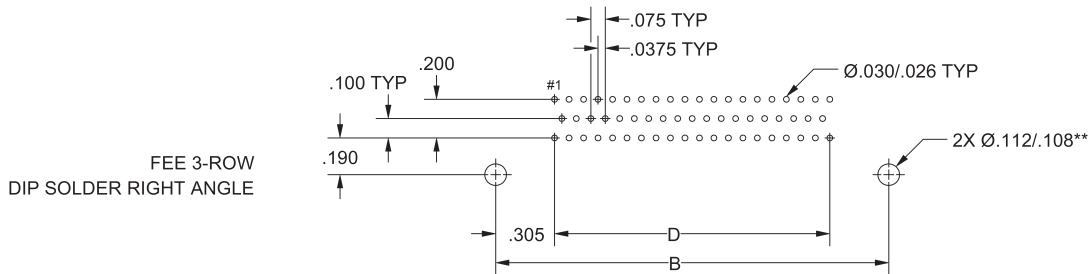
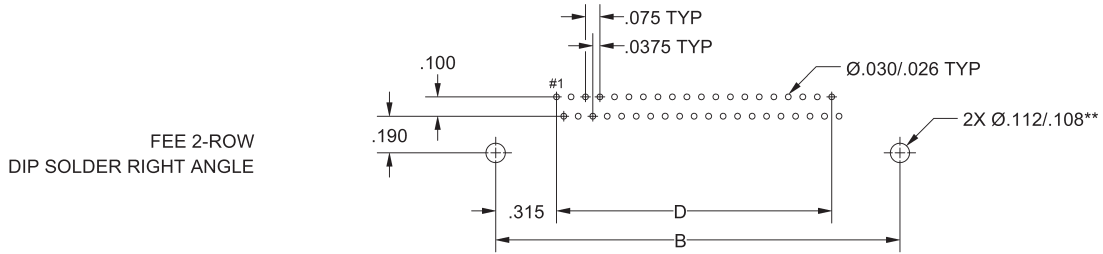

*REQUIRED HOLE SIZE FOR COMPLIANT TERMINATION STYLE CONTACTS. FOR ALL OTHERS, HOLE SIZE SUBJECT TO USER MODIFICATION FOR APPLICATION OR ALTERNATIVE STANDARDS.

**RECOMMENDATION. MAY BE MODIFIED FOR APPLICATION OR ALTERNATIVE STANDARDS.



IEH CORPORATION

140 58TH STREET, 8E, BROOKLYN, NY 11220

PHONE (718) 492-4448 • FAX (718) 492-9898

www.iehcorp.com • ieh@iehcorp.com